



**ZEAL EDUCATION SOCIETY'S**  
**ZEAL COLLEGE OF ENGINEERING AND RESEARCH**  
**NARHE | PUNE -41 | INDIA**



**5.3.2 Average number of sports and cultural programs in which students of the Institution participated during AY 2019-20 (organised by the institution/other institutions)**

Date of event/activity (DD-MM-YYYY)	Name of the event/activity	Name of the student participated
03-07-2019	Batmobile	Ajinkya Atpalkar
		Saurabh Avhad
		Shubham Babar
		Kapil Hajare
		Koushik More
		Vinod Shinde
		Sahil Pinjari
		Shubham Rane
		Vishal Raut
		Sairaj Sarode
		Siddik Shaikh
		Siddhesh Shimpi
Vivek Tanpure		
24-12-2019	Zeal Annual Sports 2019 - Basketball - Runner up	Indrajeet Rajeshirke
		Sanket Lonare
24-12-2019	Zeal Annual Sports 2019 - Volleyball - Winner	Pratapsing Chavan
		Vipul Nanaware
24-12-2019	Zeal Annual Sports 2019 - Cricket - Winner	Ram Nichal
		Suraj Undage
24-12-2019	Zeal Annual Sports 2019 - Kabbaddi - Winner	Amey Chendke
		Omkar Khandagale
24-12-2019	Zeal Annual Sports 2019 - Football - Runner up	Atharva Agashe
		Sanket Lonare
2019-20	Best Physique (Men) Tournament - 70 Kg Category	Gole Aditya
		Chandrashekhar
	Best Physique (Men) Tournament - 70 Kg Category	Gole Aditya
		Chandrashekhar



  
Prof. S. M. Godase  
HOD – Mechanical



**ZEAL EDUCATION SOCIETY'S  
ZEAL COLLEGE OF ENGINEERING AND RESEARCH  
NARHE | PUNE -41 | INDIA**



To,  
The Principal,  
ZCOER, Narhe.

Subject: - Submission of One page report

Respected Sir,

Batmobile is regarded as the ultimate superhero car in the DC Comics Universe. The indestructible Batmobile has featured in many movies and with every new movie, the vehicle only becomes more aggressive looking. Batmobile is a fantasy thing just like the superheroes but there are many who would love to experience the life of a superhero! There are many replica Batmobiles around the world. In India, a group of students have made a replica of the latest Batmobile and it looks insane!

The project is funded by the college and is made from scratch by a group of students. The Batmobile looks quite realistic in the videos and it gets all the bling on the outside too. Talking about the vehicle itself, everything has been made by the in-house team including the roll cage of the vehicle. To start with, the students first made a scale model of the Batmobile, which was used as a reference to make the life-size model of the Batmobile. The project took around 50 days to complete, which is a very short time for such a project. The total cost? According to the video, it took only Rs 3.58 lakhs for the whole project.

Regards,

Dr.A.B.Ubale

HOD Mechanical Engineering

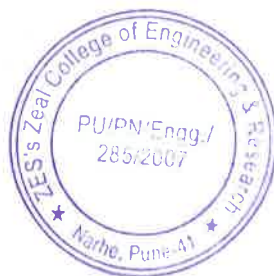

Zeal College of engineering and Research Narhe, Pune, institute has maintained high standards of effective teaching learning and self development of students. For application of the theoretical knowledge to practical world

When it comes to sustained growth, innovation is key and, in this endeavour, new products are designed and developed by industries as per the evolving market needs. Small business and large enterprise invest time, effort, resources, and a substantial amount of money to design, manufacture, and assemble electronics and other types of new-age industrial products that are optimized for functioning even in harsh environments.

New product designing includes system components design, assembly of the product, checking of the individual components, final assembly and testing. The process of product design involves activities such as deciding on the mechanical architecture, selecting materials and processes that meet the environmental requirements, engineering the various components that are necessary to make the product work, and finalizing the look and feel of the product.

Development, on the other hand, involves identifying new opportunities in the market and building products that appeal to the needs of the selected market. The focus of a product design and development process lies in refining or modifying the products to a final prototype and testing.

Developing new products is an involved task. It is not only time-consuming and costly but a huge risk to investment if the right resources are not involved. Hence, it is crucial to involve experts with proficient technical skills who have rich experience in product design and development. The leadership of the product development companies and teams should have prior experience in strategy formulation and implementation in product commercialization.

With the help of product development companies that render such spec to product engineering services, dynamic products can be designed with efficiency and ease. They can also assist with the evolution of the mission-critical designs by conducting in-depth research, and by putting in the hours required for the engineering, prototyping, modifying, or re-testing of the product.

User-centric design and effective development using state of the art technology encourage customers to see the true benefit and value of the products. The quality and performance of your products can significantly help your business to perform to its optimal best and gain an edge over competitors.

Based on the above grounds and the enthusiasm of the students together decided that we will make something innovative and challenging task. By keeping in view we find the batmobile tumbler car which is not only a complex in designing but manufacturing is also very difficult based on the existing resources available in and near to the Pune.

Nothing was available when a team of students, staff and Faculty members were started the execution this project. Based on a toy car every minute details of external panels were designed. After a lot market survey based on the market survey the engine is finalized as Mahindra Xylo engine with 2498 cc and its hub are finalized as wheel hub.



One by one all chassis members are designed and manufactured, engine , transmission line and wheels are assembled and then started the design and manufacturing the body panel. Before the final assembly non coated panels were mounted on the vehicle and testing was done. Once the testing is completed satisfactorily panels were powder coated and final assembly is done. The inauguration of the vehicle is done on 3 July 2019. The project was started on 21 April 2019.

Till today vehicle is kept for demonstration at various placed and more than 100K views are present in an online and off line mode.





Student preparing and manufacturing model

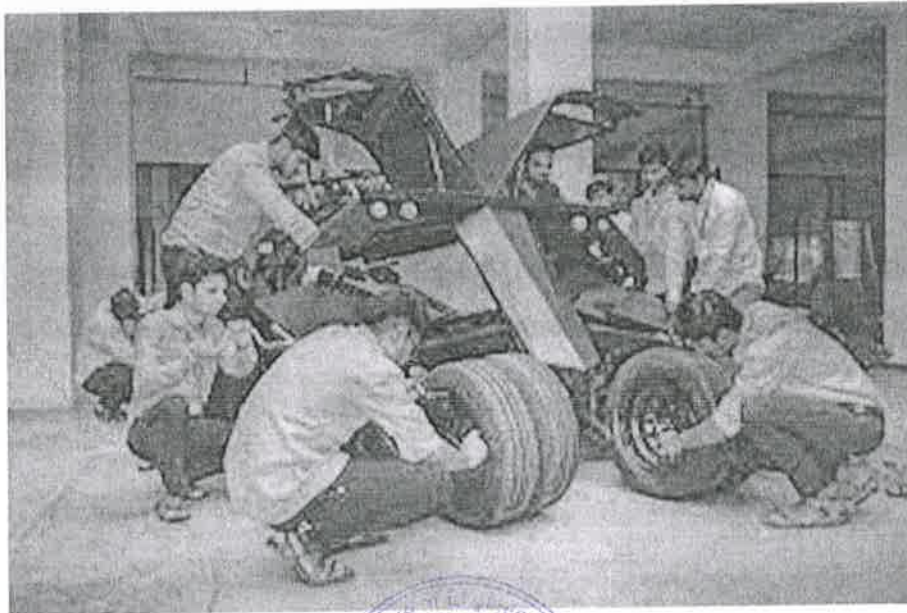

Student preparing and manufacturing model





# Media Coverage

Video Link:

<https://www.youtube.com/watch?v=hMuFhyf7rSE>

<https://www.youtube.com/watch?v=Bkfm8ZwYie8>

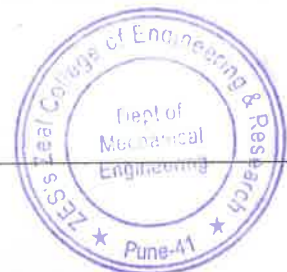

माझा महाराष्ट्र

झील एज्युकेशन सोसायटीच्या विद्यार्थ्यांचा प्रयोग  
पुण्यातील चार विद्यार्थ्यांनी तयार केली  
देशातील पहिली हॅंडमेड बॅटमोबिल कार

छविनिर्माता: पुणः

पुण्यातील झील एज्युकेशन सोसायटीच्या विद्यार्थ्यांनी तयार केलेली बॅटमोबिल कार. ही कार देशातील पहिली हॅंडमेड बॅटमोबिल कार आहे. ती पुण्यातील झील एज्युकेशन सोसायटीच्या विद्यार्थ्यांनी तयार केली आहे. ही कार देशातील पहिली हॅंडमेड बॅटमोबिल कार आहे.



राष्ट्रीय झील एज्युकेशन सोसायटीच्या विद्यार्थ्यांनी तयार केलेली बॅटमोबिल कार.

पुण्यातील झील एज्युकेशन सोसायटीच्या विद्यार्थ्यांनी तयार केलेली बॅटमोबिल कार. ही कार देशातील पहिली हॅंडमेड बॅटमोबिल कार आहे. ती पुण्यातील झील एज्युकेशन सोसायटीच्या विद्यार्थ्यांनी तयार केली आहे.

पुण्यातील झील एज्युकेशन सोसायटीच्या विद्यार्थ्यांनी तयार केलेली बॅटमोबिल कार. ही कार देशातील पहिली हॅंडमेड बॅटमोबिल कार आहे. ती पुण्यातील झील एज्युकेशन सोसायटीच्या विद्यार्थ्यांनी तयार केली आहे.

पुण्यातील झील एज्युकेशन सोसायटीच्या विद्यार्थ्यांनी तयार केलेली बॅटमोबिल कार. ही कार देशातील पहिली हॅंडमेड बॅटमोबिल कार आहे. ती पुण्यातील झील एज्युकेशन सोसायटीच्या विद्यार्थ्यांनी तयार केली आहे.

पुण्यातील झील एज्युकेशन सोसायटीच्या विद्यार्थ्यांनी तयार केलेली बॅटमोबिल कार. ही कार देशातील पहिली हॅंडमेड बॅटमोबिल कार आहे. ती पुण्यातील झील एज्युकेशन सोसायटीच्या विद्यार्थ्यांनी तयार केली आहे.



HINDUSTAN TIME'S PUNE THURSDAY JULY 04 2009

PUNE IN NUMBERS 5,864



Batmobile, designed by the mechanical engineering students of Zeal College of Engineering and Research, on display at Navi path, on Wednesday.

STYLE QUOTIENT OF PUNE STREETS REVED UP WITH A 'BATMOBILE'

PUNE: Mechanical engineering students of Zeal College of Engineering and Research inaugurated their 'Batmobile' on Wednesday at Pune. A team of four students under the guidance of faculty members designed and manufactured an off-road car resembling the Batmobile. It is a hand-made concept car derived from the super hero movie Batman. The car is hand-made by synthesizing 25 different vehicles components. It is a 3-wheeled speed of 120 kmph. Along with the team of four students, there was a supporting team of faculty and instructors who have contributed as well. Lead Designer, head of mechanical department of Zeal College of Engineering and Research. The students who worked on this project are in their final year of mechanical engineering - Sudhesh Shinde, Anurag Kulkarni, Vivek Gaurav and Vedant Jagtap. Vivek Gaurav said "This was our wish had theoretical knowledge but after working on this project many new concepts and ideas emerged." The car which seats two has a 200cc diesel engine. The estimate has applied for a patent for this car.

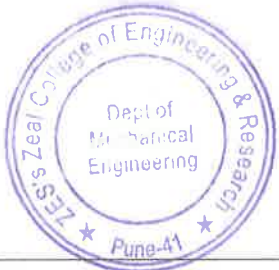



To,  
The Principal,  
ZCOER,  
Narhe; Pune-41.

Date: 17/4/2019

(197)

**Sub:** Funding amount required for **UTV Car** project work.

**Project Name:** Design and development of **Batmobile Car (Tumbler)** for college.

Respected Sir,

As mentioned above subject faculties of Mechanical Department are going to design & develop **Batmobile Car (Tumbler)** for college. The detail expenditure for manufacturing of car is given below.

Sr. No	Description	Quantity	Approx Cost	Total
1	Old Car	1	1,00,000	1,00,000
2	Car maintenance and assembling		90000	90000
3	Chassis Material	200ft	120000	120000
4	Hub Manufacturing	2	20000	40000
5	Suspension	4	20000	80000
6	Fabrication Cost		80000	80000
7	Wheel and Tyres	4	25000	100000
8	Body work and painting		120000	120000
9	Tools and Consumables		20000	20000
10	miscellaneous		50000	50000
<b>Total</b>				<b>8,00,000/-</b>

Kindly sanction the amount **Rs-8,00,000/-** for same.

Thanking You.

Prof.P.A.Parit

Forwarded  
to Prof. P. A. Parit  
Dr.A.B.Übale

HOD Mech

Dr.A.M.Kate

Principal ZCOER

Mr.P.V.Khandave

Executive Director ZES



To,  
The Principal,  
ZCOER,  
Narhe; Pune-41.

Date: 17/4/2019

**Sub:** Full time dedicated team required for **UTV Car** project work.  
Project Name: Design and development of **Batmobile Car (Tumbler)** for college.

Respected Sir,

As mentioned above subject faculties of Mechanical Department are going to design & develop **Batmobile Car (Tumbler)** for college. As time given for completion of project is only one month (i.e.30/05/19). Considering this deadline we required fulltime staff for this project. List of staff is given below.

Sr. No	Name	Designation	Role in Project
1	Dr. Amol Ubale	HOD	Project Head & Guide
2	Prof. Pravin Parit	Assistant Professor	Design
3	Prof. Mahendra Kalyanshetti	Assistant Professor	CAD Design
4	Prof. Suhas Sawant	Assistant Professor	CAD Design
5	Prof. Sushil Kamble	Teaching Assistant	CAD Design
6	Mr.Pravin Lendve	Workshop Staff	Welder
7	Mr.Haridas Lendeve		Welder
8	Mr.Ghadge		Welder
9	Mr.Namdev Kumbhar	Peon	Helper
10	Mr.Ramdas Kadu	Peon	Helper

Kindly allow above staff for this project. .

Thanking You.

Prof.P.A.Parit

*Forwarded to principal for consideration.*

Dr.A.B.Ubale

HOD Mech



Dr.A.M.Kate

Principal ZCOER

Mr.P.V.Khandave

Executive Director ZES



**ZEAL EDUCATION SOCIETY'S**  
**ZEAL COLLEGE OF ENGINEERING AND RESEARCH,**  
**NARHE | PUNE -41 | INDIA**

**DEPARTMENT OF MECHANICAL ENGINEERING**

24/04/2019

Ref

To,

The Principal,

Zocer, Narhe, Pune.

Sub:- About getting permission to following students and staff for Batmobile project

Respected sir,

As per the discussion with you, we require following students and staff members to work on the bat mobile project work. So I request you to consider this and do the needful

Sr. No.	Name	Designation in team
1	Dr. Amol Ubale	Project coordinator
2	Prof. Parit Pravin	Team member and workshop incharge for project
3	Prof. kalyanshetty Mahendra	CAD Designer
4	Prof. Savant Suhas	Team member and purchase incharge
5	Mr. Lendave Pravin	Welder
6	Mr. Lendave Haridas	Welder
7	Mr. Kamble Sushil	CAD Designer
8	Atpalkar Ajinkya Nandkishor	Student members
9	Avhad Saurabh Shankar	Student members
10	Babar Shubham Pradeep	Student members
11	Kapil Gorakhanath Hajare	Student members
12	Koushik Sanjay More	Student members
13	Shind Shiddhesh Vinod	Student members
14	Sahil Gulamnabi Pinjari	Student members
15	Shubham Sandesh Rane	Student members

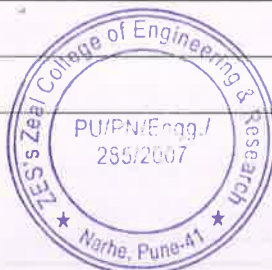



**ZEAL EDUCATION SOCIETY'S**  
**ZEAL COLLEGE OF ENGINEERING AND RESEARCH,**  
**NARHE | PUNE -41 | INDIA**

**DEPARTMENT OF MECHANICAL ENGINEERING**

16	Vishal Jagannath Raut	Student members
17	Sairaj Hanuman Sarode	Student members
18	Siddik Mahmadalim Shaikh	Student members
19	Siddhesh Rajendra Shimpi	Student members
20	Vivek Prakash Tanpure	Student members

Approved By

  
**Dr. Ajit Kate**  
Principal



Yours' sincerely

  
**Dr. A. B. Ubale**  
Associate Proff. And Head Of Dept.  
Mechanical Engineering Dept.

# Zeal College of Engg. & Res. 2019-20

39, Narhe Village, Pune -411041

## BAJA / Sufara ATV Vehicle

Ledger Account

1-Apr-2019 to 31-Jul-2019

Page 1

Date	Particulars	Vch Type	Vch No.	Debit	Credit
20-4-2019	Cr <b>Metal Point</b> BEING INV.NO.17765 RECD.FOR MS PIPE FOR BATMOBILE CAR - MECH.DEPT.	Journal	54	13,154.00	
29-4-2019	Cr <b>Metal Point</b> BEING INV.NO.17827 RECD.FOR MS SHEET FOR BATMOBILE CAR - MECH. DEPT.	Journal	72	6,331.00	
15-5-2019	Cr <b>Abhyudaya Co-Op Bank 3398 ZCOER</b> Payment Cheque 15-5-2019 89,990.00 Cr CHQ.NO. : 111959, BEING PAID AGNST. PUR.OF OLD XYLO CAR FOR BATMOBILE CAR PARTS (TUMBLER) - MECH.DEPT. TO CONCEPT MOTORS.		652	89,990.00	
21-5-2019	Cr <b>Cash (Engineering College)</b> BEING CASH PAID TO AMOL UBALE TOWARDS EXP INCURRED FOR DETAILS ENCLOSED. ZCOER/05/	Payment	695	69,441.00	
29-5-2019	Cr <b>Metal Point</b> BEING INV.NO.18039 RECD.FOR MS SHEET FOR <u>BATMOBILE CAR - MECH.</u> DEPT.	Journal	174	22,567.00	
12-6-2019	Cr <b>Metal Point</b> BEING INV.NO.18167 RECD.FOR MS ANGLE FOR <u>BATMOBILE CAR - MECH.</u> DEPT.	Journal	224	8,180.00	
13-6-2019	Cr <b>Electro Power System</b> BEING INV.NO.593 RECD.FOR EXITE BATTERY FOR BATMOBILE CAR (MECH.)	Journal	229	5,500.00	
19-6-2019	Cr <b>Cash (Engineering College)</b> BEING CASH PAID TO AMOL UBALE TOWARDS DETAIL BILLS ENCLOSED. ZCOER/06/	Payment	913	65,928.00	
24-6-2019	Cr <b>Cash (Engineering College)</b> BEING CASH PAID TO AMOL UBALE TOWARDS BATMOBILE CAR AS PER DETAILS ENCLOSED. ZCOER/06/	Payment	950	42,903.00	
				3,23,994.00	
Dr	<b>Closing Balance</b>				3,23,994.00
				3,23,994.00	3,23,994.00



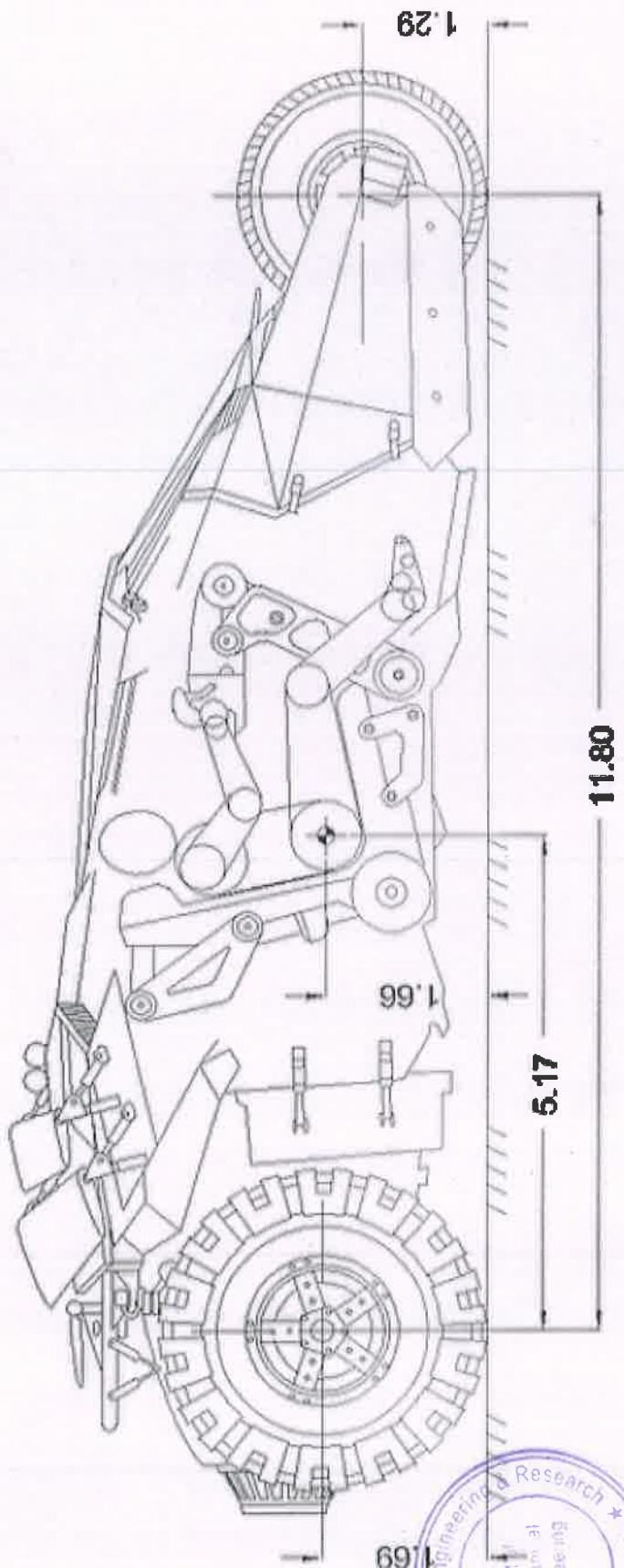
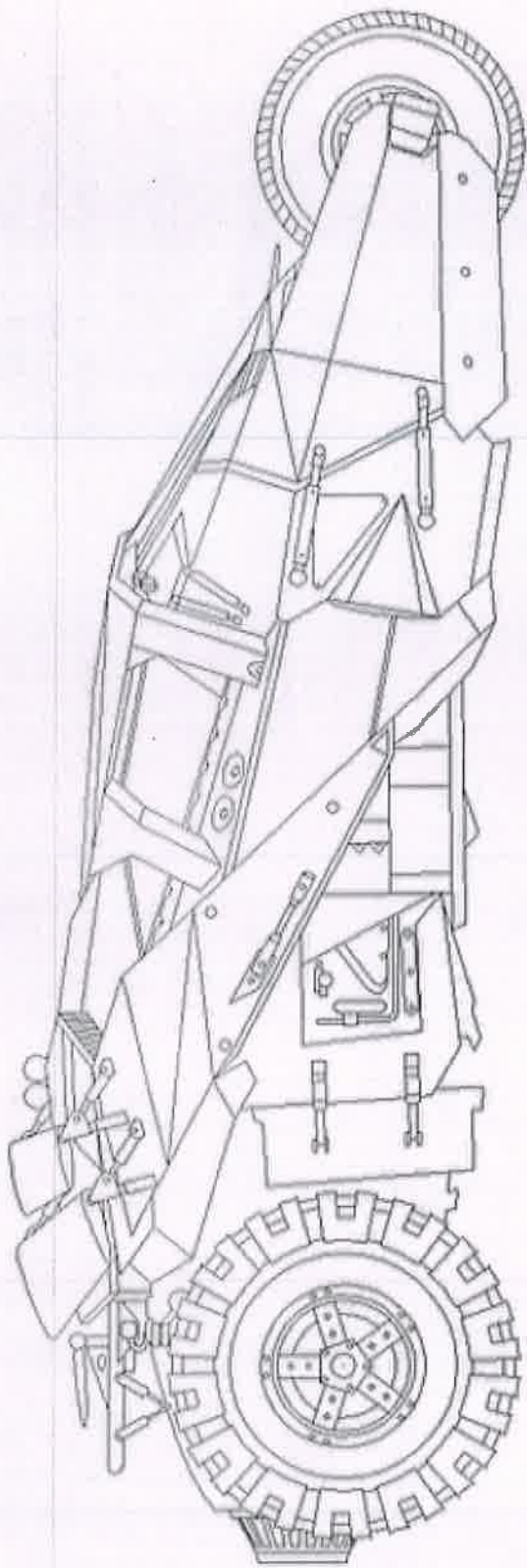

691



TITLE: TUMBLER

ASSIGNMENT: 9

UNITS: FEET



A

m

c

D

4

3

2

1

60

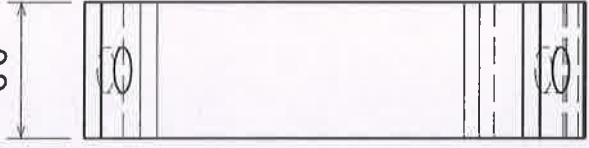

Left view  
Scale: 1:3

Front view  
Scale: 1:3

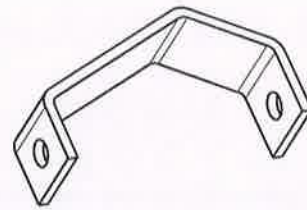
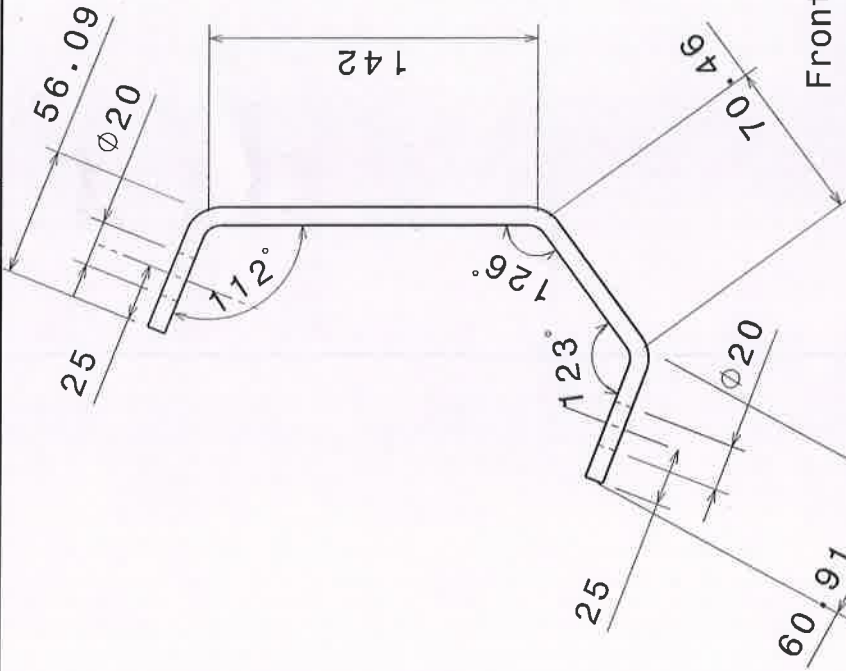

Isometric view  
Scale: 1:5

# bat-mobile

DESIGNED BY: admin	DATE: 5/14/2019	CHECKED BY: XXX	DATE: XXX	SIZE: A4	WEIGHT (kg): XXX	DRAWING NUMBER: XXX	SHEET: 1/1
cc-clamp				1			
1:1				A			

This drawing is our property; it can't be reproduced or communicated without our written agreement.



A

D



A B C D

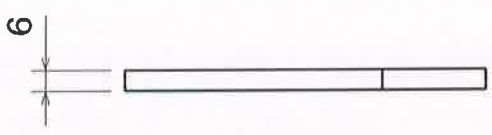

4 3 2 1

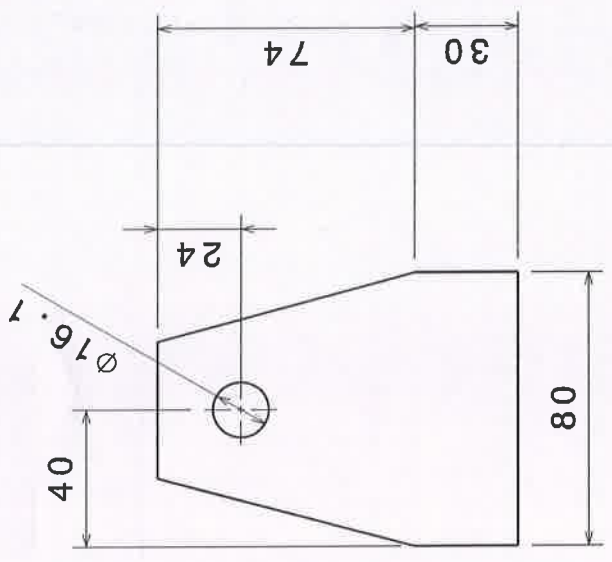

Front view  
Scale: 1:2



Left view  
Scale: 1:2

DESIGNED BY:	admin	Rear cross Mbr Support	
DATE:	5/18/2019	 	
CHECKED BY:	XXX		
DATE:	XXX		
SIZE	A4	BATMOBILE CAR	SHEET
SCALE	1:1	WEIGHT (kg)	1/1
DRAWING NUMBER		Rear cross mbr support	
This drawing is our property; it can't be reproduced or communicated without our written agreement.			



D A







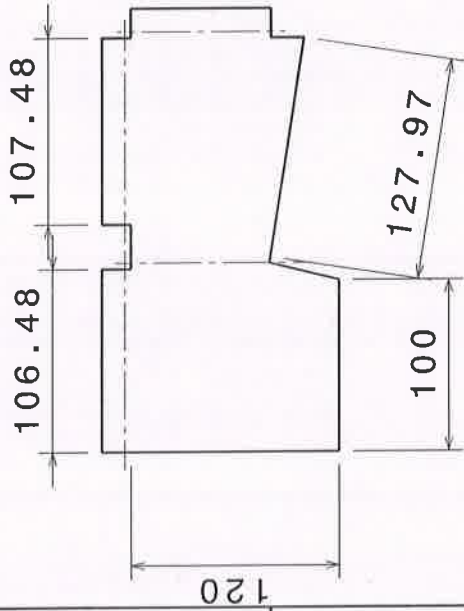

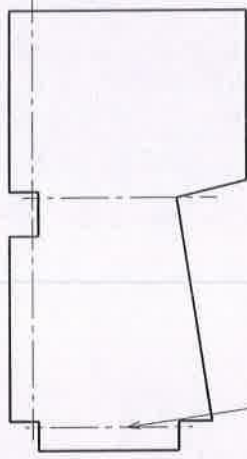

LH--Unfolded view  
Scale: 1:4

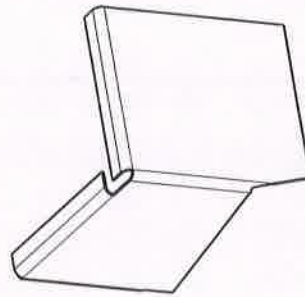

All bend angle 90 deg  
RH--Unfolded view  
Scale: 1:4



Isometric view  
Scale: 1:4

DESIGNED BY: admin			SIZE <b>A4</b>	SCALE <b>1:1</b>	WEIGHT (kg) <b>XXX</b>	DRAWING NUMBER <b>XXX</b>	SHEET <b>1/1</b>	A	
DATE: 6/12/2019	CHECKED BY: XXX							DATE: XXX	B
<h1 style="text-align: center;">batmobile</h1>								C	
<h2 style="text-align: center;">front middle panel</h2>								D	
<p style="text-align: center;">This drawing is our property; it can't be reproduced or communicated without our written agreement.</p>								E	
								F	
								G	
								H	
								I	



A

B

C

D

4

3

2

1

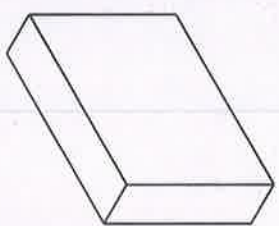

Isometric view  
Scale: 1:1

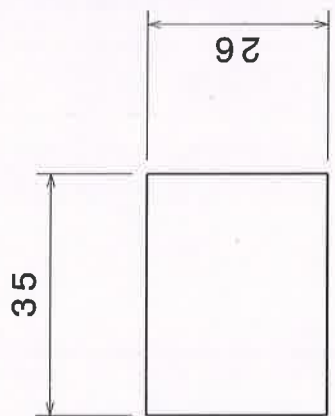

Front view  
Scale: 1:1



Top view  
Scale: 1:1

DESIGNED BY: admin			DRAWING NUMBER	SHEET				
DATE: 5/31/2019	CHECKED BY: XXX				XXX	1/1		
DATE: XXX	DATE: XXX							
SIZE: A4	SCALE: 1:1	WEIGHT (KG): XXX						
<h1>BATMOBILE</h1>		<h2>Support Block</h2>						
					<p>This drawing is our property; it can't be reproduced or communicated without our written agreement.</p>			
I	H	G	F	E	D	C	B	A



A

D

A

B

C

D

4

3

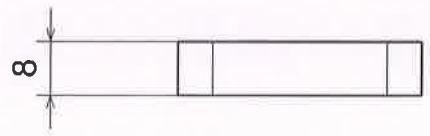

Left view  
Scale: 1:1

$\phi 35$

R5

35

Front view  
Scale: 1:1

203.2

Qty. 2 no.

2

1

DESIGNED BY:	admin	B		I
DATE:	5/31/2019			
CHECKED BY:	XXX	Str_con_rod_2		H
DATE:	XXX			
SIZE	A4	Str_con_rod_2		G
SCALE	1:1			
		XXX		F
		XXX		E
		XXX		D
		XXX		C
		XXX		B
		XXX		A

# BATMOBILE



DRAWING NUMBER

WEIGHT (kg)

SHEET

1:1

XXX

1/1



This drawing is our property; it can't be reproduced or communicated without our written agreement.

D

A

A

B

C

D

4

3

2

1

177.8

R5  
Ø16

Ø16

Ø16

17.5

20

20

35

17.5

Front view  
Scale: 1:3

355.6

Isometric view  
Scale: 1:4

∞

Top view  
Scale: 1:3

Qty:2 no.

DESIGNED BY:	admin		DRAWING NUMBER	SHEET
DATE:	5/31/2019			
CHECKED BY:	XXX			
DATE:	XXX	WEIGHT (kg)	XXX	1/1
SIZE	A4	SCALE	1:1	XXX
BATMOBILE		Str_con_rod		
I	-	A	-	-
H	-	B	-	-
G	-	C	-	-
F	-	D	-	-
E	-	E	-	-
D	-	F	-	-
C	-	G	-	-
B	-	H	-	-
A	-	I	-	-

This drawing is our property; it can't be reproduced or communicated without our written agreement.



A

D



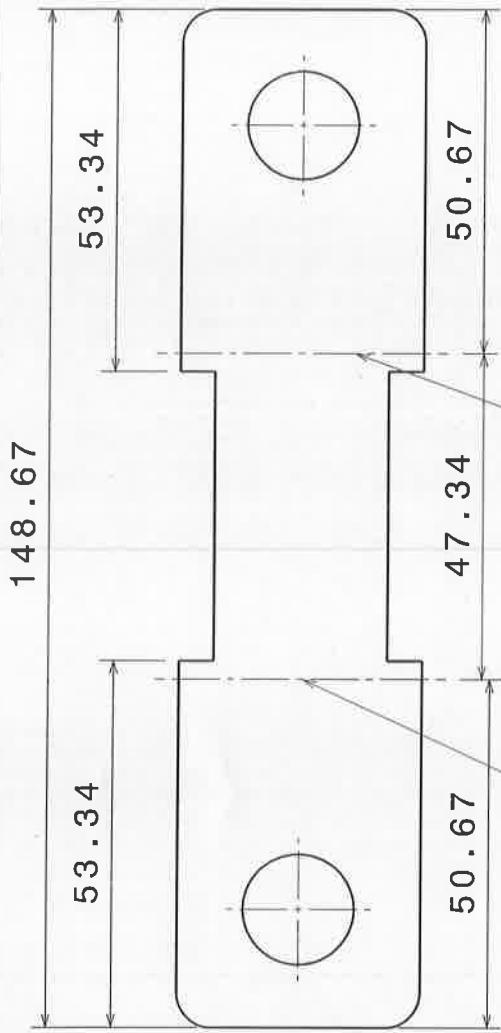
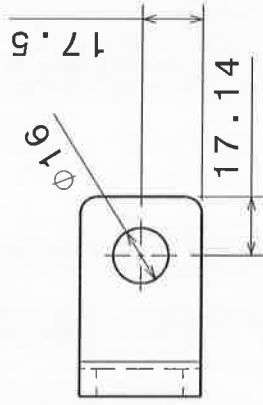
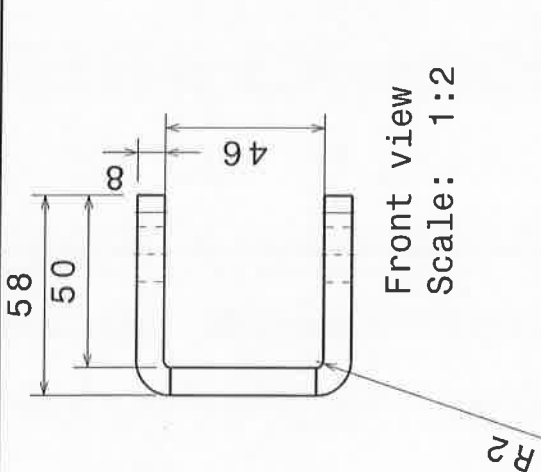

Bend Angle 90 deg

DESIGNED BY: admin	DATE: 5/31/2019			DRAWING NUMBER: XXX	SHEET: 1/1
CHECKED BY: XXX	DATE: XXX				
SIZE: A4	SCALE: 1:1	WEIGHT (kg): XXX			
<b>BATMOBILE</b>			<b>C-Clamp_1</b>		
I	H	G	F	E	D
C	B	A			

This drawing is our property; it can't be reproduced or communicated without our written agreement.



A

C

D

4

3

2

1

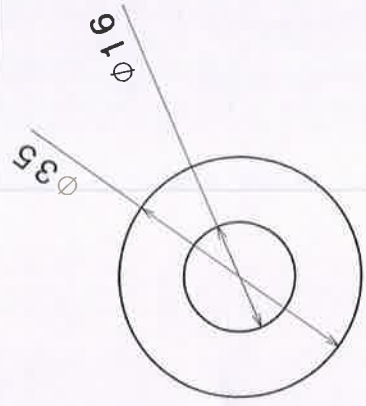

Front view  
Scale: 1:1



Top view  
Scale: 1:1

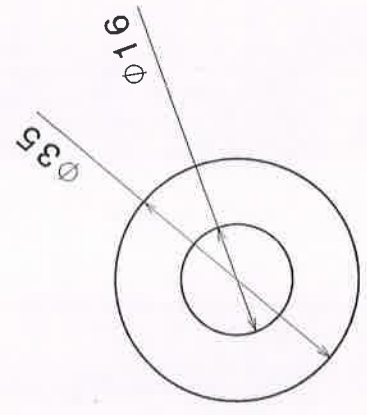

Front view  
Scale: 1:1

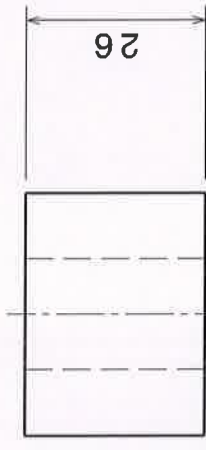

Top view  
Scale: 1:1

**BUSH**

**BATMOBILE**

**BUSH Center**



DESIGNED BY: admin	DATE: 5/31/2019			DRAWING NUMBER	SHEET
CHECKED BY: XXX	DATE: XXX				
SIZE: A4	SCALE: 1:1	WEIGHT (kg): XXX	A		
This drawing is our property; it can't be reproduced or communicated without our written agreement.					

A

D

4

3

2

1

A B C D E F G H

4 3 2 1 4 3 2 1 4 3 2 1

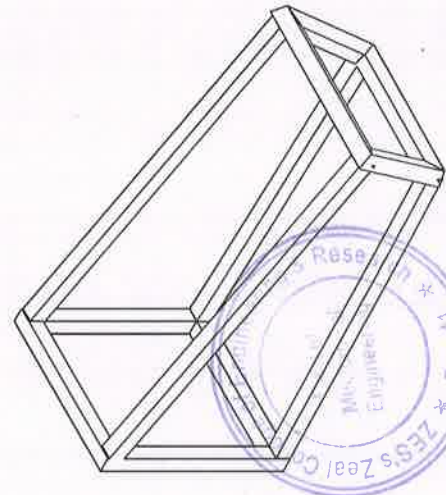
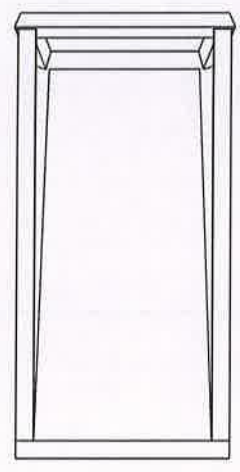
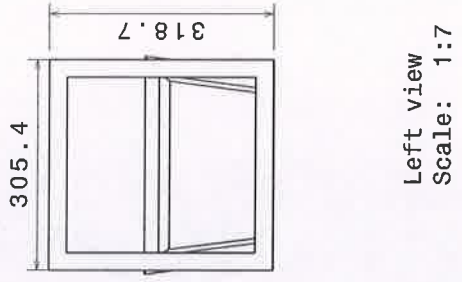
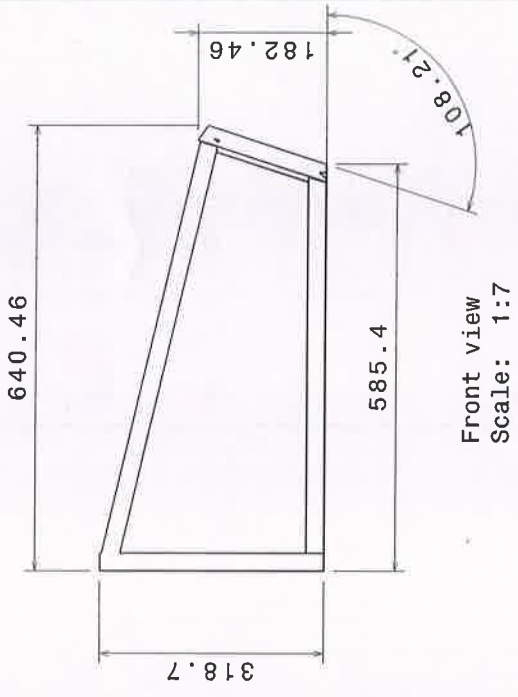
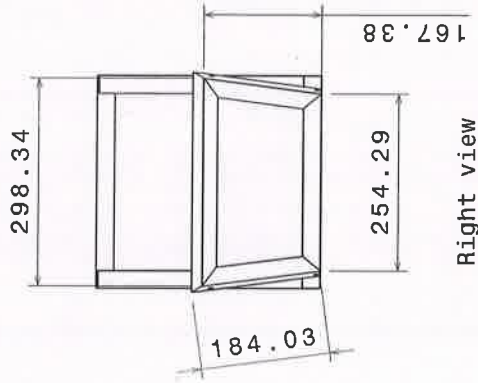

Top view  
Scale: 1:7

DESIGNED BY:	admin
DATE:	5/22/2019
CHECKED BY:	XXX
DATE:	XXX
SIZE:	A3
SCALE:	1:1
PROJECT (PG):	0.22
DRAWING NUMBER:	Nose frame
SHEET:	1/1
nose frame	

This drawing is our property. It can't be reproduced or communicated without our written agreement.

H G B A

A

B

C

D

Bend Angle-150 deg

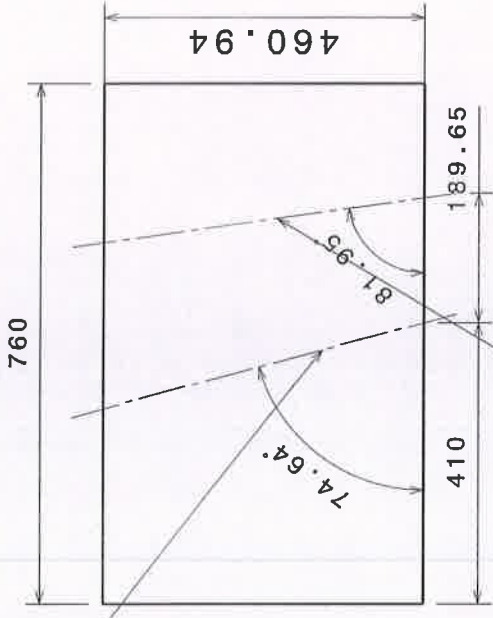

Bend angle-160 deg

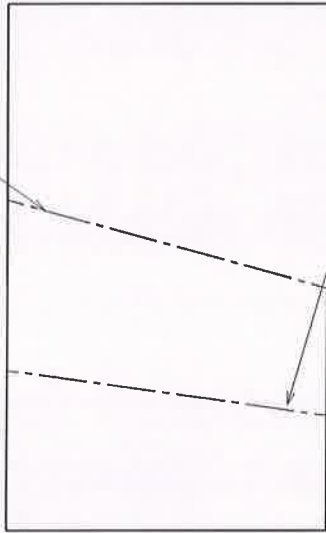



LH-Unfolded view  
Scale: 1:10

RH-Unfolded view  
Scale: 1:10

2

2

DESIGNED BY: <b>admin</b>	DATE: <b>5/24/2019</b>	CHECKED BY: <b>XXX</b>	DATE: <b>XXX</b>	 SIZE <b>A4</b>	 WEIGHT (kg) <b>XXX</b>	DRAWING NUMBER <b>XXX</b>	SHEET <b>1/1</b>
<b>BATMOBILE</b>							
<b>Sheet_55</b>							
This drawing is our property; it can't be reproduced or communicated without our written agreement.							



D

A

4

4

3

3

1

1

I

H

G

F

E

D

C

B

A

A

C

D

4

3

2

1

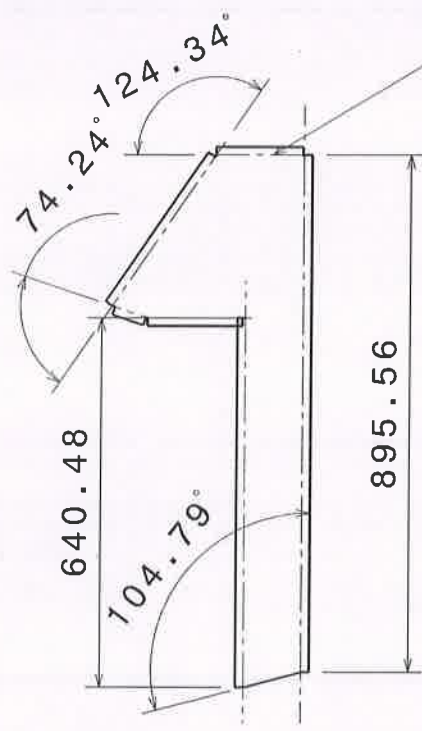

LH Unfolded view  
Scale: 1:12

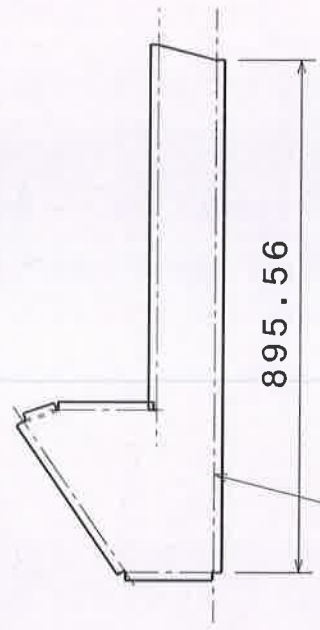

RH Unfolded view  
Scale: 1:12



Isometric view  
Scale: 1:12

DESIGNED BY: admin		DATE: 6/4/2019		CHECKED BY: XXX		DATE: XXX		SIZE: A4		WEIGHT (Kg): XXX		DRAWING NUMBER: XXX		SHEET: 1/1	
<b>BATMOBILE</b>										Side Lower Sheet					
I	H	G	F	E	D	C	B	A							

This drawing is our property; it can't be reproduced or communicated without our written agreement.

D

A

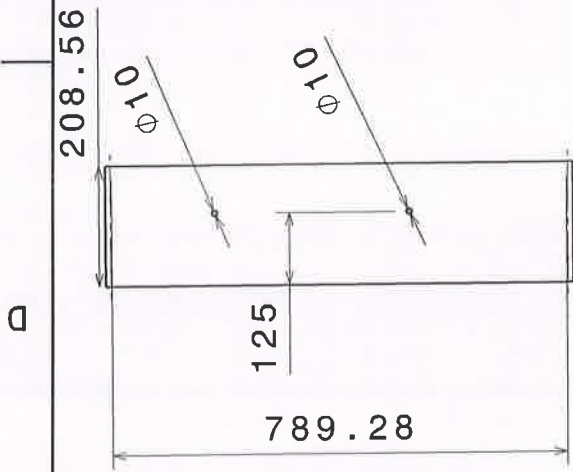

LH Unfolded view  
Scale: 1:12

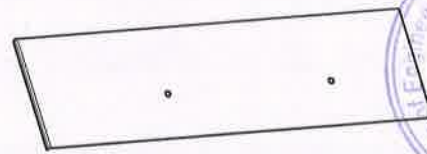

Isometric view  
Scale: 1:12

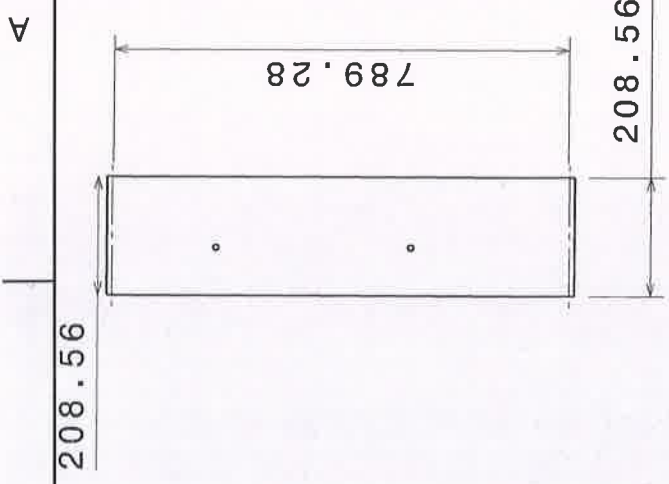

RH Unfolded view  
Scale: 1:12

DESIGNED BY: admin	BATCH NO. 2019		DATE: 6/4/2019		DRAWING NUMBER		SHEET 1/1		A								
CHECKED BY: XXX											DATE: XXX	SCALE: A4	WEIGHT (kg): XXX	SIZE: 1:1	XXX		
BATCH NO. 2019					DATE: 6/4/2019					DRAWING NUMBER		SHEET 1/1		A			
DESIGNED BY: admin					DATE: 6/4/2019					DRAWING NUMBER		SHEET 1/1		A			
CHECKED BY: XXX					DATE: XXX					SCALE: A4		WEIGHT (kg): XXX		SIZE: 1:1		XXX	
BATCH NO. 2019					DATE: 6/4/2019					DRAWING NUMBER		SHEET 1/1		A			





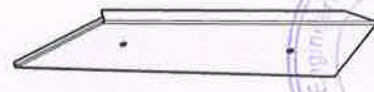
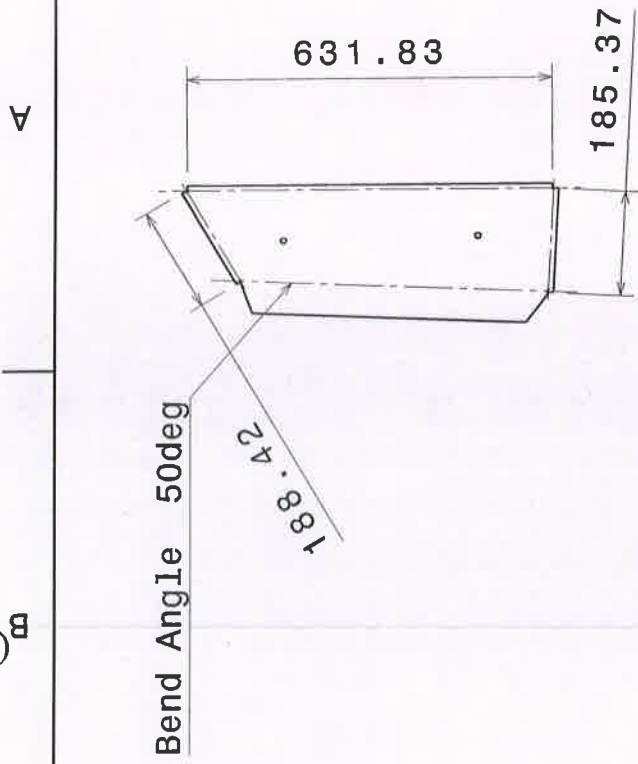
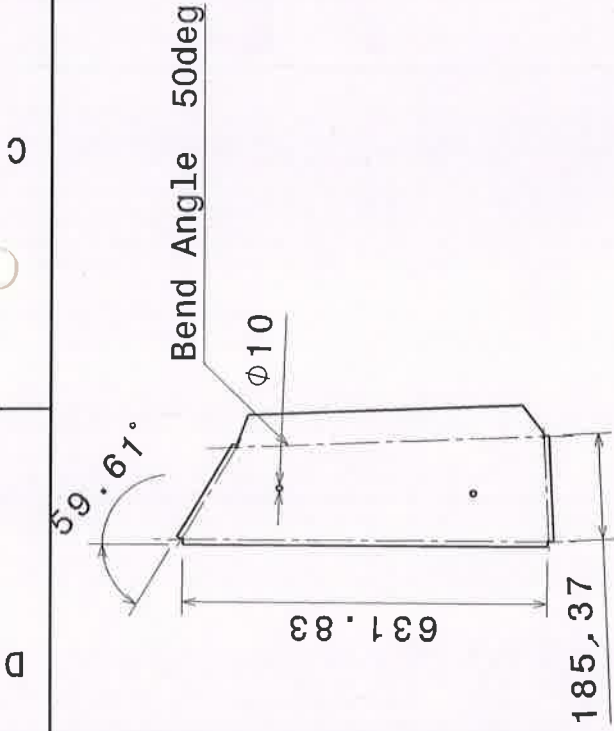

# BATMOBILE

## Side Sheet 3

This drawing is our property; it can't be reproduced or communicated without our written agreement.

D A



DESIGNED BY: admin	 	 	 	I	-
DATE: 6/4/2019				H	-
CHECKED BY: XXX				G	-
DATE: XXX	A4	1:1	XXX	F	-
	SCALE	WEIGHT (kg)	DRAWING NUMBER	E	-
	1:1	XXX	XXX	D	-
				C	-
				B	-
				A	-

# BATMOBILE

## Side sheet 2

This drawing is our property; it can't be reproduced or communicated without our written agreement.



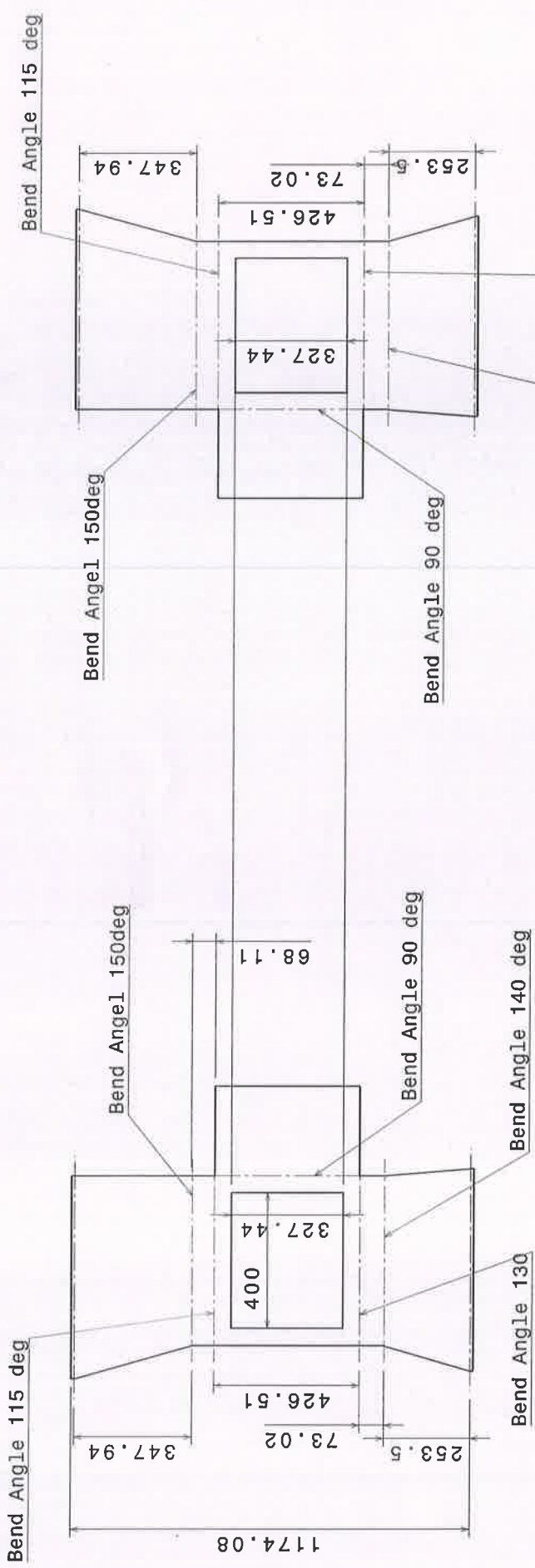

Customer: admin	DATE: 6/4/2019	CHECKED BY: XXX	DATE: XXX	SIZE: A3	WEIGHT (KG):	QUANTITY NUMBER:	SHEET:
				SCALE: 1:1	0.61	side sheet 1	1/1
<p>THIS drawing is our property. It can't be reproduced or communicated without our written agreement.</p>							



Grid lines: A, B, C, D, E, F, G, H, I (vertical); 1, 2, 3, 4 (horizontal)

A

B

C

D

760

760

330.2

77.21°

99.99°

330

200

330

330

200

77.21°

99.99°

330.2

LH Unfolded view  
Scale: 1:10

RH Unfolded view  
Scale: 1:10



Isometric view  
Scale: 1:10

DESIGNED BY: admin	DATE: 5/24/2019	CHECKED BY: XXX	DATE: XXX		DRAWING NUMBER	SHEET
SIZE: A4						
BATMOBILE				Sheet_55		
				XXX		1/1
This drawing is our property; it can't be reproduced or communicated without our written agreement.						

A

D

4

3

2

1

4

3

2

1



**ZEAL**  
 GROUP OF INSTITUTES  
 www.zealeducation.com

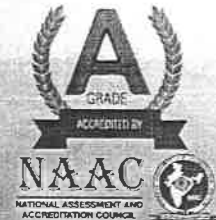

**COLLEGE OF ENGINEERING AND RESEARCH**  
**Zeal Annual Sports Meet - 2019**

(Inter-Departemental Sports Tournament)



**CERTIFICATE OF APPRECIATION**

Mr. / Ms. Indrajeet Rajeshirke is a **WINNER** /  
**RUNNER UP** in Basketball Game for the A. Y. 2018-19 held during 01/01/2019 to 06/01/2019.

*A. Kate*

Dr. A. M. Kate  
 Principal,  
 ZCOER, Pune

*(S. A. Deokar)*

Dr. S. A. Deokar  
 Campus Director,  
 Zeal Education Society, Pune

*J. S. Katkar*

Prof. J. S. Katkar  
 Executive Director,  
 Zeal Education Society, Pune



**ZEAL**  
GROUP OF INSTITUTES  
www.zealeducation.com



# ZEAL COLLEGE OF ENGINEERING AND RESEARCH

## Zeal Annual Sports Meet - 2019

(Inter-Departmental Sports Tournament)



### CERTIFICATE OF APPRECIATION

Mr. / Ms.

*Sanket Lonare*

is a **WINNER** /

**RUNNER UP** in *Basketball*

Game for the A. Y. 2018-19 held during 01/01/2019 to 06/01/2019.



Dr. A. M. Kate  
Principal,  
ZCOER, Pune



Dr. S. A. Deokar  
Campus Director,  
Zeal Education Society, Pune



Prof. J. S. Katkar  
Executive Director,  
Zeal Education Society, Pune



**ZEAL**  
**GROUP OF INSTITUTES**  
 www.zealeducation.com



**ZEAL COLLEGE OF ENGINEERING AND RESEARCH**  
**Zeal Annual Sports Meet - 2019**

*(Inter-Departemental Sports Tournament)*



**CERTIFICATE OF APPRECIATION**

Mr. / Ms. Pratapsing Chavan

RUNNERUP in Volleyball Game for the A. Y. 2018-19 held during 01/01/2019 to 06/01/2019.

is a **WINNER** /

*A. Kate*

Dr. A. M. Kate  
 Principal,  
 ZCOER, Pune

*(S. A. Deokar)*

Dr. S. A. Deokar  
 Campus Director,  
 Zeal Education Society, Pune

*J. S. Katkar*

Prof. J. S. Katkar  
 Executive Director,  
 Zeal Education Society, Pune



**ZEAL**  
GROUP OF INSTITUTES  
www.zealeducation.com

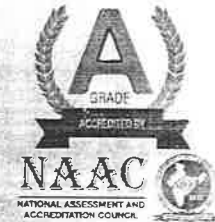

**ZEAL COLLEGE OF ENGINEERING AND RESEARCH**  
**Zeal Annual Sports Meet - 2019**

(Inter-Departemental Sports Tournament)



**CERTIFICATE OF APPRECIATION**

Mr. / Ms.

*Vipul Nanaware*

is a WINNER /

RUNNER UP in

*Volleyball*

Game for the A. Y. 2018-19 held during 01/01/2019 to 06/01/2019.

*A. Kate*

Dr. A. M. Kate  
Principal,  
ZCOER, Pune

*(S. A. Deokar)*

Dr. S. A. Deokar  
Campus Director,  
Zeal Education Society, Pune

*J. S. Katkar*

Prof. J. S. Katkar  
Executive Director,  
Zeal Education Society, Pune



**ZEAL**  
**GROUP OF INSTITUTES**  
 www.zealeducation.com

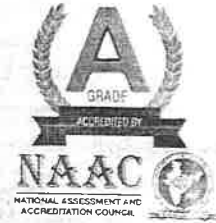

**ZEAL COLLEGE OF ENGINEERING AND RESEARCH**  
**Zeal Annual Sports Meet - 2019**

(Inter-Departemental Sports Tournament)



**CERTIFICATE OF APPRECIATION**

Mr. / Ms. Ram Nichal

**RUNNER UP** in Cricket

Game for the A. Y. 2018-19 held during 01/01/2019 to 06/01/2019.



*A. Kate*

Dr. A. M. Kate  
 Prindpal,  
 ZCOER, Pune

*(S.A. Deokar)*

Dr. S. A. Deokar  
 Campus Director,  
 Zeal Education Society, Pune

*J. S. Katkar*

Prof. J. S. Katkar  
 Executive Director,  
 Zeal Education Society, Pune



**ZEAL**  
**GROUP OF INSTITUTES**  
www.zealeducation.com



**ZEAL COLLEGE OF ENGINEERING AND RESEARCH**  
**Zeal Annual Sports Meet - 2019**

(Inter-Departemental Sports Tournament)



**CERTIFICATE OF APPRECIATION**

Mr. / Ms.

*Suraj Undage*

is a WINNER /

RUNNER UP in

*Cricket*

Game for the A. Y. 2018-19 held during 01/01/2019 to 06/01/2019.

*A. Kate*

Dr. A. M. Kate  
Principal  
ZCOER, Pune

*S. A. Deokar*

Dr. S. A. Deokar  
Campus Director,  
Zeal Education Society, Pune

*J. S. Katkar*

Prof. J. S. Katkar  
Executive Director,  
Zeal Education Society, Pune





**ZEAL**  
GROUP OF INSTITUTES  
www.zealeducation.com



**ZEAL COLLEGE OF ENGINEERING AND RESEARCH**

**Zeal Annual Sports Meet - 2019**

(Inter-Departemental Sports Tournament)



**CERTIFICATE OF APPRECIATION**

Mr. / Ms. Amey Chendke

~~RUNNER UP~~ in Kabaddi Game for the A. Y. 2018-19 held during 01/01/2019 to 06/01/2019.



*A. Kate*

Dr. A. M. Kate  
Principal,  
ZCOER, Pune

*(S. A. Deokar)*

Dr. S. A. Deokar  
Campus Director,  
Zeal Education Society, Pune

*J. S. Katkar*

Prof. J. S. Katkar  
Executive Director,  
Zeal Education Society, Pune



**ZEAL**  
GROUP OF INSTITUTES  
www.zealeducation.com



**ZEAL COLLEGE OF ENGINEERING AND RESEARCH**  
**Zeal Annual Sports Meet - 2019**

(Inter-Departemental Sports Tournament)



**CERTIFICATE OF APPRECIATION**

Mr. / ~~Mrs.~~ Omkar Khandagale

is a **WINNER /**

**RUNNER UP** in Kabaddi Game for the A. Y. 2018-19 held during 01/01/2019 to 06/01/2019.



Dr. A. M. Kate  
Principal  
ZCOER, Pune

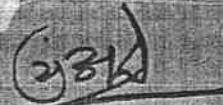

Dr. S. A. Deokar  
Campus Director,  
Zeal Education Society, Pune



Prof. J. S. Katkar  
Executive Director,  
Zeal Education Society, Pune



**ZEAL**  
GROUP OF INSTITUTES  
www.zealeducation.com



# ZEAL COLLEGE OF ENGINEERING AND RESEARCH

## Zeal Annual Sports Meet - 2019

(Inter-Departemental Sports Tournament)



### CERTIFICATE OF APPRECIATION

Mr. / Ms. Atharya Agashe

RUNNER UP in Football

Game for the A. Y. 2018-19 held during 01/01/2019 to 06/01/2019.

is a **WINNER** /



Dr. A. M. Kate  
Principal,  
ZCOER, Pune

Dr. S. A. Deokar  
Campus Director,  
Zeal Education Society, Pune

Prof. J. S. Katkar  
Executive Director,  
Zeal Education Society, Pune



# ZEAL GROUP OF INSTITUTES

www.zealeducation.com



## ZEAL COLLEGE OF ENGINEERING AND RESEARCH

# Zeal Annual Sports Meet - 2019

(Inter-Departemental Sports Tournament)



### CERTIFICATE OF APPRECIATION

Mr. / ~~Mrs.~~ Sanket Lonare

is a **WINNER** /

**RUNNER UP** in Football

Game for the A. Y. 2018-19 held during 01/01/2019 to 06/01/2019.

Dr. A. M. Kate  
Principal,  
ZCOER, Pune

Dr. S. A. Deokar  
Campus Director,  
Zeal Education Society, Pune

Prof. J. S. Katkar  
Executive Director,  
Zeal Education Society, Pune

AIU-19174



# Savitribai Phule Pune University

## Board of Sports & Physical Education



# Certificate

(All India Inter University)  
(Individual & Team Event)

This is to certify that *Gole Aditya Chandrashekhar* of the *Zeal College of Engineering & Research, Narhe, Pune* was selected as a member of the *Savitribai Phule Pune University Team* which participated in the *All India Inter-University Best Physique (Men)* tournament held at *Chandigarh University, Mohali (Punjab)* during the academic year *2019-2020*.

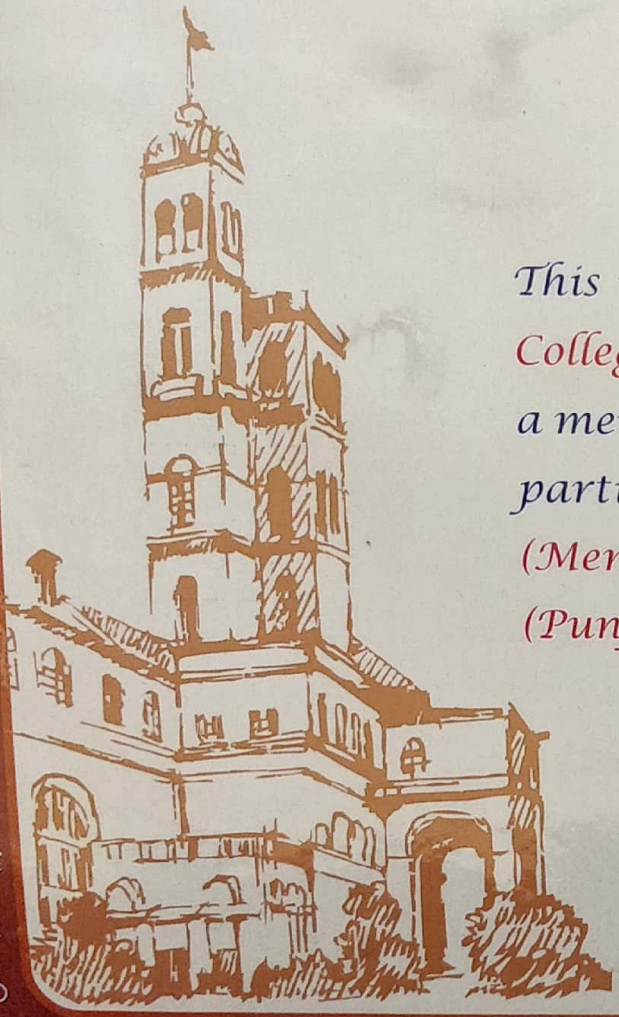

*M. S.*  
Director,  
Board of Sports &  
Physical Education



*G. S. Phule*  
President  
Board of Sports &  
Physical Education

Scanned with CamScanner

# Savitribai Phule Pune University

## Pune District Zonal Sports Committee

357



Inter Zonal Sports

### Certificate of Participation



This is to certify that Mr. / Miss Gole Aditya Chandrashekhar

of Zeal College Narhe

has represented Pune District Zonal Sports Committee in the Inter Zonal Best-Physique

competition held at C.D. Jain college, Shrirampur during the academic year 2019-20

*Dhamale*

**Dr. Girish Dhamale**

Hon. Secretary

Pune District Zonal Sports Committee, Pune

Verified & Sign.



*Shewale*

**Prin. Shrikant Shewale**

President

Pune District Zonal Sports Committee, Pune