



ZEAL EDUCATION SOCIETY'S
ZEAL COLLEGE OF ENGINEERING AND RESEARCH
NARHE | PUNE -41 | INDIA



DEPARTMENT OF MECHANICAL ENGINEERING

SUMMARY REPORT OF HANDS ON TRAINING ACADEMIC YEAR: 2020-21

| Sr. No. | Value added courses | Date of Introduction | Duration of course (Hours) | Number of Students completing the course in the year |
|---------|---------------------------|---------------------------|----------------------------|--|
| 1 | CAM/CAM/CAE (CATIA V5R21) | 17/01/2021- to 26/03/2021 | 38 | 75 |
| | | 17/05/2021 to 26/06/2021 | 40 | 75 |



(Signature)

Head of Department
Head of Department
Dept. of Mechanical Engineering
ZES's Zeal College of Engineering
& Research, Pune-41



**ZEAL EDUCATION SOCIETY'S
ZEAL COLLEGE OF ENGINEERING AND RESEARCH
NARHE | PUNE -41 | INDIA**



DEPARTMENT OF MECHANICAL ENGINEERING

Hands on Training on Computer Aided Design (CAD) CATIA V5R21

Index

| Sr. No | Particulars |
|---------------|---------------------------|
| 1 | Course Details |
| 2 | Course Content |
| 3 | Notice |
| 4 | List of students enrolled |
| 5 | Schedule |
| 6 | Student attendance |
| 7 | Evaluation Details |
| 8 | Activity Summary Report |
| 9 | Certificate |



**ZEAL EDUCATION SOCIETY'S
ZEAL COLLEGE OF ENGINEERING AND RESEARCH
NARHE | PUNE -41 | INDIA**



DEPARTMENT OF MECHANICAL ENGINEERING

COURSE DETAILS

| | | |
|---|--------------------------|---|
| 1 | Course Name | Hands on Training on Computer Aided Design (CAD) - Catia V5 R21 |
| 2 | Duration | 38 Hrs |
| 3 | Date | 17.01.21- 26.03.21 |
| 4 | Students enrolled | 75 |
| 5 | Learners | BE |

Course Coordinator

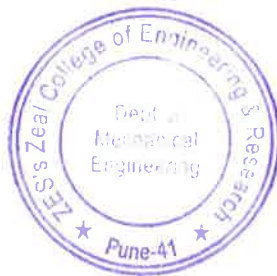

Head of the Department
Head of Department
Dept. of Mechanical Engineering
ZES's Zeal College of Engineering
& Research, Pune-411 041



**ZEAL EDUCATION SOCIETY'S
ZEAL COLLEGE OF ENGINEERING AND RESEARCH
NARHE | PUNE -41 | INDIA**



DEPARTMENT OF MECHANICAL ENGINEERING

Notice (Hands on Training)

Date: 02/01/2021

Hands on training program on “**Computer Aided Design (CAD) - Catia V5 R21**” for TE & BE students will be conducted from **17.01.21- 26.03.21** in the Department of Mechanical Engineering. The interested students can register to department on or before 12/01/2021.

Course Coordinator

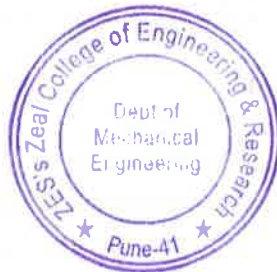

**Head of the Department
Head of Department
Dept. of Mechanical Engineering
ZES's Zeal College of Engineering
& Research, Pune-411 041**



ZEAL EDUCATION SOCIETY'S
ZEAL COLLEGE OF ENGINEERING AND RESEARCH
NARHE | PUNE -41 | INDIA
DEPARTMENT OF MECHANICAL ENGINEERING



List of the Students Enrolled for Hands on Training on CAM/CAM/CAE (CATIA V5R21)

Academic Year: 2020-21

Duration of Course: 38 Hours (17.01.21- 26.03.21)

Class : BE
SEM- II

| S.No. | Name |
|-------|---------------------------------|
| 1 | ABHINKAR ATHARVA NILESH |
| 2 | ABUZAR ABDUL HAI |
| 3 | AJMIRE PRAJWAL KISHOR |
| 4 | BARBHAJ ANIKET KISHOR |
| 5 | BARIDE PURUSHOTTAM RADHAKRISHNA |
| 6 | BAVISKAR AMIT ANIL |
| 7 | BHALERAO SWAPNIL DAYANAND |
| 8 | BHARGUDE ABHISHEK HARISHCHANDRA |
| 9 | BHATTA RUTWIK KAILASH |
| 10 | BHOSALE SUMIT HANMANT |
| 11 | BHURE NAGESH SURYAKANT |
| 12 | BIDVE ABHIJIT SUNIL |
| 13 | BIRAJDAR PRASAD BALAJI |
| 14 | CHAVAN PRATAPSIH PARMESHWAR |
| 15 | DEOKAR ATHARVA SANJAYKUMAR |
| 16 | DESHPANDE RAJ SUNIL |
| 17 | DHAIGUDE ANUP PANDURANG |
| 18 | DHIRAJ SWARUP DHUMAL |
| 19 | DHUMAL PRATHAMESH DATTATRAY |
| 20 | DOIPHODE PRAJTIK KAILASH |
| 21 | GALANDE AVADHOOT BHARAT |
| 22 | GAWADE AMAR GURUNATH |
| 23 | GAWADE UDAY KIRAN |
| 24 | GHUME SHRJAY SUNIL |
| 25 | GODSE ISHWANKU SANJAY |



(Signature)

Course Co-ordinator

Head of Department
Department of Mechanical Engineering
ZES's Zeal College of Engineering
& Research, Pune-411 041



ZEAL EDUCATION SOCIETY'S
ZEAL COLLEGE OF ENGINEERING AND RESEARCH
NARHE | PUNE -41 | INDIA
DEPARTMENT OF MECHANICAL ENGINEERING



List of the Students Enrolled for Hands on Training on CAM/CAM/CAE (CATIA V5R21)

Academic Year: 2020-21

Duration of Course: 38 Hours (17.01.21- 26.03.21)

Class : BE
SEM-**I**

| S.No. | Name |
|-------|----------------------------|
| 1 | AMANGI CHARUDATTA UDAY |
| 2 | A WALE SHUBHAM SHIVAJI |
| 3 | BHURE VARUN DILIPBHAI |
| 4 | BINGUNDI ANIRUDH SHRINIWAS |
| 5 | BIRAJDAR VISHAL ANIL |
| 6 | CHANDANSHIVE AKASH VASANT |
| 7 | CHAVAN POOJA HAJIMALANG |
| 8 | DAIVADNYA GAYATRI MANOHAR |
| 9 | DHENE DINESH POPAT |
| 10 | DUDHANE PRASAD PRAKASH |
| 11 | FUTANE PRASANNA RAM |
| 12 | GAJARE VINAYAK POPAT |
| 13 | GARAD ANIKET SUDAM |
| 14 | GHUTE DIVYARAJ MEGHRAJ |
| 15 | GOGAWALE TANMAY PRASHANT |
| 16 | JADHAV RAJVEER HIMMAT |
| 17 | JAGATAP ABHISHEK RAJENDRA |
| 18 | JAGTAP PRASAD MAHADEV |
| 19 | JARIKOTE MAHESH BALAJI |
| 20 | JAWALGIKAR ISHA DATTATRAYA |
| 21 | KADAM PRATIK SANJAY |
| 22 | KALE ANAND JAGJEEVAN |
| 23 | KHIRID SUJIT DNYANESHWAR |
| 24 | KOCHARI ATHARV SHIVANAND |
| 25 | KORPAD PREM PRAMOD |



Course Co-ordinator

Head of Department
Dept. of Mechanical Engineering
ZES's Zeal College of Engineering & Research



ZEAL EDUCATION SOCIETY'S
ZEAL COLLEGE OF ENGINEERING AND RESEARCH
NARHE | PUNE -41 | INDIA
DEPARTMENT OF MECHANICAL ENGINEERING



List of the Students Enrolled for Hands on Training on CAM/CAM/CAE (CATIA V5R21)

Academic Year: 2020-21

Duration of Course: 38 Hours (17.01.21- 26.03.21)

Class : BE
SEM-**I**

| S.No. | Name |
|-------|---------------------------------|
| 1 | DESHMUKH KRUSHNA ACHUTRAO |
| 2 | KALE SURAJ SUNIL |
| 3 | KUNVAR KRUNALBHAI DILIPBHAI |
| 4 | NIGADE ROHIT SHIVAJI |
| 5 | PANDIT OMKAR SOMANATH |
| 6 | PARAB SWAPNIL RAVINDRA |
| 7 | PATIL DEVENDRA SUDHAKAR |
| 8 | PATIL HINDURAO KESHA VRAO |
| 9 | PATIL JAGRUT BHAGWAT |
| 10 | PATIL MAHESH UMESH |
| 11 | PATIL SAURABH SUBHASH |
| 12 | PATIL SNEHA SUNIL |
| 13 | PATIL VISHWAJEET MANIKRAO |
| 14 | PAYGUDE OMKAR ASHOK |
| 15 | PHALKE MAHESH PRADIP |
| 16 | PRATIK SANJAY PULUJKAR |
| 17 | RAJESHIRKE INDRAJEET SHASHIKANT |
| 18 | RAJVADE ROHIT DATTA TRAY |
| 19 | RAJWADE RAHUL DILIP |
| 20 | RAJPUROHIT DHANESH RAMSINGH |
| 21 | RANSING SOHAM SANTOSH |
| 22 | RAUT SOURABH BALKRUSHNA |
| 23 | REKHALE PRASHANT SHRIMANT |
| 24 | SONAWANE NILESH SHIVAJI |
| 25 | SUKI SHANKAR SANDESH |



[Signature]

Course Co-ordinator

[Signature]
Head of Department
Dept. of Mechanical Engineering
ZES's Zeal College of Engineering
& Research, Pune-41



DEPARTMENT OF MECHANICAL ENGINEERING

Notice (Hands on Training schedule)

Date: 14/01/2021

All enrolled students for Hands on training program on “**Computer Aided Design (CAD) - Catia V5 R21**” are informed that training is scheduled from 17/01/2021 to 26/03/2021. Please find list of batch wise enrolled students on respective WhatsApp group.

| Batch | Time |
|--------------|---------------------|
| 1 | 1.00 to 3.00 |
| 2 | 3.00 to 5.00 |
| 3 | 5.00 to 7.00 |

Course Coordinator

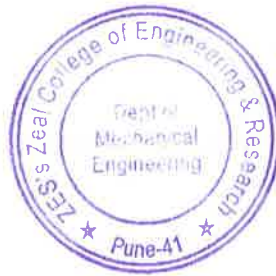

**Head of the Department
Head of Department
Dept. of Mechanical Engineering
ZES's Zeal College of Engineering
& Research, Pune-411 041**



**ZEAL EDUCATION SOCIETY'S
ZEAL COLLEGE OF ENGINEERING AND RESEARCH
NARHE | PUNE -41 | INDIA**



DEPARTMENT OF MECHANICAL ENGINEERING

Schedule

| Week | DAY | Details of Module |
|--------|-----|--|
| Week 1 | 1 | Sketching Modelling |
| | 2 | Introduction to 2D&3D, Basic concepts. Introduction to Unigraphics NX, User interface, WCS, Absolute coordinate Application. |
| | 3 | Sketching commands, Sketch positioning, Basic idea behind constraints, |
| | 4 | Sketching Practice session |
| | 5 | Part Modeling |
| | 6 | Extrude, Revolve, Edge Blend, Chamfer, |
| Week 2 | 7 | Hole,Datums(Point, Axis, Plane) , Draft body ,Shell, Pattern (Linear , circular),Rib, Sweep Along Guide, |
| | 8 | Variational sweep, Swept, Edit work section, copy feature, paste, scale body, selection filter |
| | 9 | Basic primitives (Block, Cylinder, Cone and Sphere,)Boss ,Pad, Pocket, Grooves lot, thread, |
| | 10 | Combine (Unit, Subtracts, Intersect),time stamp order, apply material, measure - bodies |
| Week 3 | 11 | Part Modeling Practice session |
| | 12 | Drafting |
| | 13 | Sheet properties, New sheet ,Edit Sheet, Base view, View Wizard, Dimensions and types, Note |
| | 14 | Projected/Auxiliary View, Section view, Detail view, View brake: breakout section ,dimension tolerances |
| | 15 | Datum, Datum target, Feature control frame, center mark, cross hatch , surface finish , weld symbol |
| | 16 | Assembly |
| Week 4 | 17 | Bottom up Assembly: Add, move Component. Assembly constraints Pattern components . |
| | 18 | Top Down: Create New, Wave geometry link, exploded view clearance, creation Assembly Drafting : BOM, Ballon |
| | 19 | TEST 1 |
| | 20 | TEST 2 |

Course Coordinator



Head of the Department
Head of Department
Dept. of Mechanical Engineering
ZES's Zeal College of Engineering
& Research, Pune-411 041



List of the Students Enrolled for Hands on Training on CAM/CAM/CAE (CATIA V5R21)

Academic Year: 2020-21

Duration of Course: 38 Hours (17.01.21- 26.03.21)

Class : BE

SEM- **I**

| S.N 0. | Name | 17 | 23 | 24 | 30 | 31 | 6 | 7 | 13 | 14 | 20 | 21 | 27 | 28 | 6 | 7 | 13 | 14 | 21 | 26 |
|-----------|-----------------------------|----|----|----|----|----|---|---|----|----|----|----|----|----|---|---|----|----|----|----|
| 1 | ABHINKAR ATHARVA NILESH | P | P | P | P | P | P | P | P | P | A | P | P | P | P | P | P | P | P | P |
| 2 | ABUZAR ABDUL HAI | P | P | P | P | P | P | P | P | P | P | P | P | P | P | P | P | P | P | P |
| 3 | AJMIRE PRAJWAL KISHOR | P | P | P | P | P | P | P | P | P | P | P | P | P | P | P | P | P | P | P |
| 4 | BARBHAI ANIKET KISHOR | P | P | P | P | P | P | P | P | P | P | P | P | P | P | P | P | P | P | P |
| 5 | BARIDE PURUSHOTTAM | P | P | P | P | P | P | P | P | P | P | P | P | P | P | P | P | P | P | P |
| 6 | BAVISKAR AMIT ANIL | P | P | P | P | P | P | P | P | P | P | P | P | P | P | P | P | P | P | P |
| 7 | BHALERAO SWAPNIL DAYANAND | P | P | P | P | P | P | P | P | P | P | P | P | P | P | P | P | P | P | P |
| 8 | BHARGUDE ABHISHEK | A | P | P | P | P | P | P | P | A | P | P | P | P | P | P | P | P | P | P |
| 9 | BHATTA RUTWIK KAILASH | A | P | P | P | P | P | P | P | P | P | P | P | P | P | P | P | P | P | P |
| 10 | BHOSALE SUMIT HANMANT | P | P | P | P | P | P | P | P | P | P | P | P | P | P | P | P | P | P | P |
| 11 | BHURE NAGESH SURYAKANT | P | P | P | P | P | P | P | P | P | P | P | P | P | P | P | P | P | P | P |
| 12 | BIDVE ABHIJIT SUNIL | P | P | P | P | P | P | P | P | P | P | P | P | P | P | P | P | P | P | P |
| 13 | BIRAJDAR PRASAD BALAJI | P | P | P | P | P | P | P | P | A | P | P | P | P | P | P | P | P | P | P |
| 14 | CHAVAN PRATAP SINH | P | P | P | P | P | P | P | P | P | P | P | P | P | P | P | P | P | P | P |
| 15 | DEOKAR ATHARVA SANJAYKUMAR | P | P | P | P | P | P | P | P | P | P | P | P | P | P | P | P | P | P | P |
| 16 | DESHPANDE RAJ SUNIL | P | P | P | P | P | P | P | P | P | P | P | P | P | P | P | P | P | P | P |
| 17 | DHAIGUDE ANUP PANDURANG | P | P | P | P | P | P | P | P | P | P | P | P | P | P | P | P | P | P | P |
| 18 | DHIRAJ SWARUP DHUMAL | P | P | P | P | P | P | P | P | P | P | P | P | P | P | P | P | P | P | P |
| 19 | DHUMAL PRATHAMESH DATTATRAY | P | P | P | P | P | P | P | P | P | P | P | P | P | P | P | P | P | P | P |
| 20 | DOIPHODE PRATIK KAILASH | P | P | P | P | P | P | P | P | P | P | P | P | P | P | P | P | P | P | P |
| 21 | GALANDE AVADHOOT BHARAT | A | P | P | P | P | P | P | P | P | P | P | A | P | P | P | P | P | P | P |
| 22 | GAWADE AMAR GURUNATH | P | P | P | P | P | P | P | P | P | P | P | P | P | P | P | P | P | P | P |
| 23 | GAWADE UDAY KIRAN | P | P | P | P | P | P | P | P | P | P | P | P | P | P | P | P | P | P | P |
| 24 | GHUME SHRIRAJ SUNIL | P | P | P | P | P | P | P | P | P | P | P | P | P | P | P | P | P | P | P |
| 25 | GODSE ISHWANKU SANJAY | P | P | P | P | P | P | P | P | P | P | P | P | P | P | P | P | P | P | P |



Course Co-ordinator

Head of Department
 Dept. of Mechanical Engineering
 ZES's Zeal College of Engineering



List of the Students Enrolled for Hands on Training on CAM/CAM/CAE (CATIA V5R21)

Academic Year: 2020-21

Duration of Course: 38 Hours (17.01.21- 26.03.21)

Class : BE
 SEM-**I**

| S.N o. | Name | 17 | 23 | 24 | 30 | 31 | 6 | 7 | 13 | 14 | 20 | 21 | 27 | 28 | 6 | 7 | 13 | 14 | 21 | 26 |
|--------|----------------------------|----|----|----|----|----|---|---|----|----|----|----|----|----|---|---|----|----|----|----|
| 1 | AMANGI CHARUDATTA UDAY | A | P | P | P | P | P | P | P | P | P | P | P | P | P | P | P | P | P | P |
| 2 | A WALE SHUBHAM SHIVAJI | P | P | P | P | P | P | P | P | P | P | P | P | P | P | P | P | P | P | P |
| 3 | BHURE VARUN DILIPBHAI | P | P | P | P | P | P | P | P | P | P | P | P | P | P | P | P | P | P | P |
| 4 | BINGUNDI ANIRUDH SHRINIWAS | P | P | P | P | P | P | P | P | P | P | P | P | P | P | P | P | P | P | P |
| 5 | BIRAJDAR VISHAL ANIL | P | P | P | P | P | P | P | P | P | P | P | P | P | P | P | P | P | P | P |
| 6 | CHANDANSHIVE AKASH VASANT | P | P | P | P | P | P | P | P | P | P | P | P | P | P | P | P | P | P | P |
| 7 | CHAVAN POOJA HAJIMALANG | P | P | P | P | P | P | P | P | P | P | P | P | P | P | P | P | P | P | P |
| 8 | DAIVADNYA GAYATRI MANOHAR | P | P | P | P | P | P | P | P | P | P | P | P | P | P | P | P | P | P | P |
| 9 | DHENE DINESH POPAT | P | P | P | P | P | P | P | P | P | P | P | P | P | P | P | P | P | P | P |
| 10 | DUDHANE PRASAD PRAKASH | P | P | P | P | P | P | P | P | P | P | P | P | P | P | P | P | P | P | P |
| 11 | FUTANE PRASANNA RAM | P | P | P | P | P | P | P | P | P | P | P | P | P | P | P | P | P | P | P |
| 12 | GAJARE VINAYAK POPAT | P | P | P | P | P | P | P | P | P | P | P | P | P | P | P | P | P | P | P |
| 13 | GARAD ANIKET SUDAM | P | P | P | P | P | P | P | P | P | P | P | P | P | P | P | P | P | P | P |
| 14 | GHUTE DIVYARAJ MEGHRAJ | P | P | P | P | P | P | P | P | P | P | P | P | P | P | P | P | P | P | P |
| 15 | GOGAWALE TANMAY PRASHANT | P | P | P | P | P | P | P | P | P | P | P | P | P | P | P | P | P | P | P |
| 16 | JADHAV RAJVEER HIMMAT | P | P | P | P | P | P | P | P | P | P | P | P | P | P | P | P | P | P | P |
| 17 | JAGATAP ABHISHEK RAJENDRA | P | P | P | P | P | P | P | P | P | P | P | P | P | P | P | P | P | P | P |
| 18 | JAGTAP PRASAD MAHADEV | P | P | P | P | P | P | P | P | P | P | P | P | P | P | P | P | P | P | P |
| 19 | JARIKOTE MAHESH BALAJI | P | P | P | P | P | P | P | P | P | P | P | P | P | P | P | P | P | P | P |
| 20 | JAWALGIKAR ISHA DATTATRAYA | A | P | P | P | P | P | P | P | P | P | P | P | P | P | P | P | P | P | P |
| 21 | KADAM PRATIK SANJAY | P | P | P | P | P | P | P | P | P | P | P | P | P | P | P | P | P | P | P |
| 22 | KALE ANAND JAGJEEVAN | P | P | P | P | P | P | P | P | P | P | P | P | P | P | P | P | P | P | P |
| 23 | KHIRID SUJIT DNYANESHWAR | P | P | P | P | P | P | P | P | P | P | P | P | P | P | P | P | P | P | P |
| 24 | KOCHARI ATHARV SHIVANAND | P | P | P | P | P | P | P | P | P | P | P | P | P | P | P | P | P | P | P |
| 25 | KORPAD PREM PRAMOD | P | P | P | P | P | P | P | P | P | P | P | P | P | P | P | P | P | P | P |



Course Co-ordinator

Head of Department
 Dept. of Mechanical Engineering
 ZES's Zeal College of Engineering



**ZEAL EDUCATION SOCIETY'S
ZEAL COLLEGE OF ENGINEERING AND RESEARCH
NARHE | PUNE -41 | INDIA
DEPARTMENT OF MECHANICAL ENGINEERING**



List of the Students Enrolled for Hands on Training on CAM/CAM/CAE (CATIA V5R21)

Academic Year: 2020-21

Duration of Course: 38 Hours (17.01.21- 26.03.21)

Class : BE

SEM-**II**

| S.N o. | Name | 17 | 23 | 24 | 30 | 31 | 6 | 7 | 13 | 14 | 20 | 21 | 27 | 28 | 6 | 7 | 13 | 14 | 21 | 26 |
|-----------|-----------------------------|----|----|----|----|----|---|---|----|----|----|----|----|----|---|---|----|----|----|----|
| 1 | DESHMUKH KRUSHNA ACHUTRAO | P | P | P | P | P | P | P | P | P | P | P | P | P | P | P | P | P | P | P |
| 2 | KALE SURAJ SUNIL | P | P | A | P | P | P | P | P | P | P | P | P | P | P | P | P | P | P | P |
| 3 | KUNVAR KRUNALBHAI DILIPBHAI | P | P | P | P | P | P | P | P | P | P | P | P | P | P | P | P | P | P | P |
| 4 | NIGADE ROHIT SHIVAJI | P | P | P | P | P | P | P | P | P | P | P | P | P | P | P | P | P | P | P |
| 5 | PANDIT OMKAR SOMANATH | P | P | P | P | P | P | P | P | P | P | P | P | P | P | P | P | P | P | P |
| 6 | PARAB SWAPNIL RAVINDRA | P | P | P | P | P | P | P | P | P | P | P | P | P | P | P | P | P | P | P |
| 7 | PATIL DEVENDRA SUDHAKAR | P | P | P | P | P | P | P | P | P | P | P | P | P | P | P | P | P | P | P |
| 8 | PATIL HINDURAO KESHAVRAO | P | P | P | P | P | P | P | P | A | P | P | P | P | P | P | P | P | P | P |
| 9 | PATIL JAGRUT BHAGWAT | P | P | P | P | P | P | P | P | P | P | P | P | P | P | P | P | P | P | P |
| 10 | PATIL MAHESH UMESH | P | P | P | P | P | P | P | P | P | P | P | P | P | P | P | P | P | P | P |
| 11 | PATIL SAURABH SUBHASH | A | P | P | P | P | P | P | A | P | P | P | P | P | P | P | P | P | P | P |
| 12 | PATIL SNEHA SUNIL | P | P | P | P | P | P | P | P | P | P | P | P | P | P | P | P | P | P | P |
| 13 | PATIL VISHWAJEET MANIKRAO | P | P | P | P | P | P | P | P | P | P | P | P | P | P | P | P | P | P | P |
| 14 | PAYGUDE OMKAR ASHOK | P | P | P | P | P | P | P | P | P | P | P | P | P | P | P | P | P | P | P |
| 15 | PHALKE MAHESH PRADIP | P | P | P | P | P | P | P | P | P | P | P | P | P | P | P | P | P | P | P |
| 16 | PRATIK SANJAY PULUJKAR | P | P | P | P | P | P | P | P | P | P | P | P | P | P | P | P | P | P | P |
| 17 | RAJESHIRKE INDRAJEET | P | P | P | P | P | P | P | P | P | P | P | P | P | P | P | P | P | P | P |
| 18 | RAJIVADE ROHIT DATTATRAY | P | P | P | P | P | P | P | P | P | P | P | P | P | P | P | P | P | P | P |
| 19 | RAJIWADE RAHUL DILIP | P | P | P | P | P | P | P | P | P | P | P | P | P | P | P | P | P | P | P |
| 20 | RAJPUROHIT DHANESH RAMSINGH | P | P | P | P | P | P | P | P | P | P | P | P | P | P | P | P | P | P | P |
| 21 | RANSING SOHAM SANTOSH | P | P | P | P | P | P | P | P | P | P | P | P | P | P | P | P | P | P | P |
| 22 | RAUT SOURABH BALKRUSHNA | P | P | P | P | P | P | P | P | P | P | P | P | P | P | P | P | P | P | P |
| 23 | REKHALE PRASHANT SHRIMANT | P | P | P | P | P | P | P | P | P | P | P | P | P | P | P | P | P | P | P |
| 24 | SONAWANE NILESH SHIVAJI | A | P | P | P | P | P | P | P | P | P | P | P | P | P | P | P | P | P | P |
| 25 | SUKI SHANKAR SANDESH | P | P | P | P | P | P | P | P | P | P | P | P | P | P | P | P | P | P | P |

Course Co-ordinator



Head of Department
Head of Department
Dept. of Mechanical Engineering
ZES's Zeal College of Engineering
& Research, Pune - 411 021



DEPARTMENT OF MECHANICAL ENGINEERING

Test on Hands on CAD/CAM/CAE (UGNX-10.0)

Academic Year: 2020-21

SEM-II

Time: 2 Hrs

Marks: 50

Q.1) Butterfly Valve Assembly: Create the components of the Butterfly Valve assembly and then assemble them, as shown in Figure 1. The dimensions of the components are shown in Figures 2 through 7. Assume the missing dimensions.

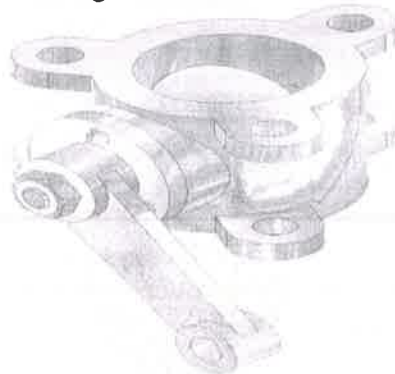

Figure 1 The Butterfly Valve assembly

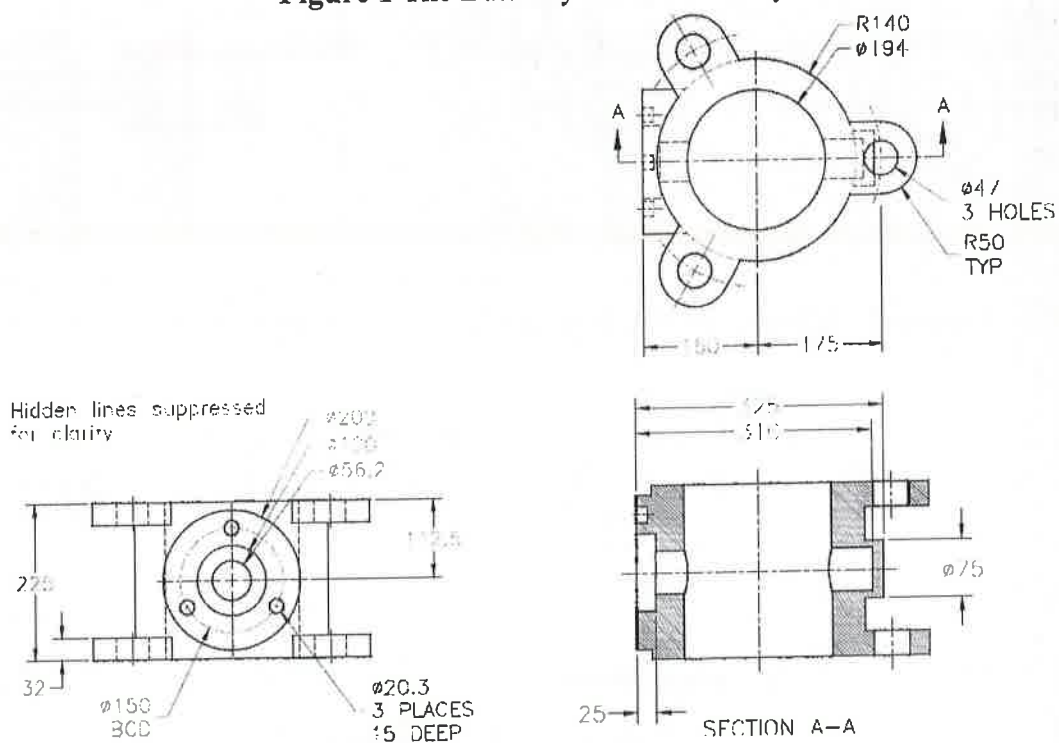
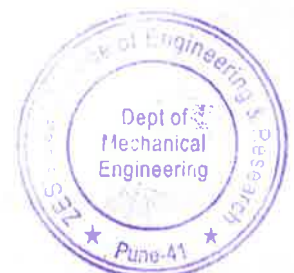

Figure 2 Dimensions of the Body





DEPARTMENT OF MECHANICAL ENGINEERING

Test on Hands on CAD/CAM/CAE (UGNX-10.0)

Academic Year: 2020-21

SEM-II

Time: 2 Hrs

Marks: 50

Q.2) Plummer Block Assembly: In this project, you will create the components of the Plummer Block assembly, as shown in Figure 1 and then assemble them. The dimensions of the components are given in Figures 2 through 4.

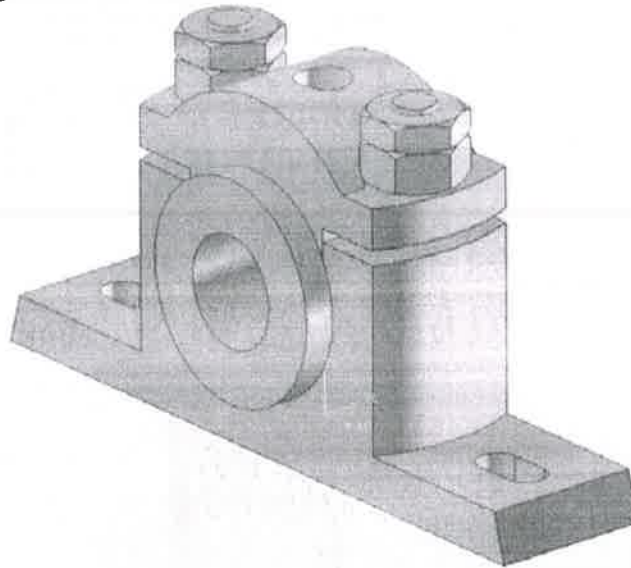

Figure 1 The Plummer Block assembly

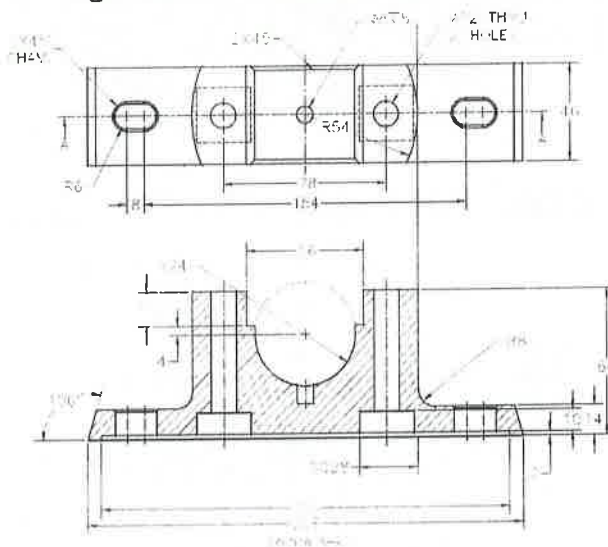

Figure 2 Views and dimensions of the Casting





**ZEAL EDUCATION SOCIETY'S
ZEAL COLLEGE OF ENGINEERING AND RESEARCH
NARHE | PUNE -41 | INDIA**



DEPARTMENT OF MECHANICAL ENGINEERING

Evaluation details of Hands on CAD/CAM/CAE (UGNX-10.0)

Academic Year: 2020-21

Duration of Course: 38 Hours (17.01.21- 26.03.21)

SEM-II

| Sr. No. | Name | Part Modelling (20) | Assembly Modelling (20) | Drafting (10) | Total Marks (50) |
|---------|---------------------------------|---------------------|-------------------------|---------------|------------------|
| 1 | ABHINKAR ATHARVA NILESH | 15 | 16 | 08 | 39 |
| 2 | ABUZAR ABDUL HAI | 14 | 14 | 07 | 35 |
| 3 | AJMIRE PRAJWAL KISHOR | 16 | 17 | 08 | 41 |
| 4 | BARBHA ANIKET KISHOR | 16 | 15 | 07 | 38 |
| 5 | BARIDE PURUSHOTTAM RADHAKRISHNA | 15 | 16 | 07 | 38 |
| 6 | BAVISKAR AMIT ANIL | 17 | 16 | 08 | 41 |
| 7 | BHALERAO SWAPNIL DAYANAND | 16 | 15 | 07 | 38 |
| 8 | BHARGUDE ABHISHEK HARISHCHANDRA | 17 | 16 | 08 | 41 |
| 9 | BHATTA RUTWIK KAILASH | 16 | 16 | 08 | 40 |
| 10 | BHOSALE SUMIT HANMANT | 15 | 16 | 07 | 38 |
| 11 | BHURE NAGESH SURYAKANT | 16 | 17 | 08 | 41 |
| 12 | BIDVE ABHIJIT SUNIL | 14 | 16 | 07 | 37 |
| 13 | BIRAJDAR PRASAD BALAJI | 17 | 18 | 07 | 42 |
| 14 | CHAVAN PRATAPSIKH PARMESHWAR | 18 | 15 | 07 | 40 |
| 15 | DEOKAR ATHARVA SANJAYKUMAR | 17 | 16 | 08 | 41 |
| 16 | DESHPANDE RAJ SUNIL | 14 | 12 | 06 | 32 |
| 17 | DHAIGUDE ANUP PANDURANG | 16 | 15 | 07 | 38 |
| 18 | DHIRAJ SWARUP DHUMAL | 15 | 14 | 07 | 36 |
| 19 | DHUMAL PRATHAMESH DATTATRAY | 18 | 12 | 07 | 42 |
| 20 | DOIPHODE PRATIK KAILASH | 16 | 17 | 08 | 41 |
| 21 | GALANDE AVADHOOT BHARAT | 15 | 14 | 07 | 36 |
| 22 | GAWADE AMAR GURUNATH | 14 | 13 | 06 | 33 |
| 23 | GAWADE UDAY KIRAN | 16 | 15 | 07 | 38 |
| 24 | GHUME SHRIJAY SUNIL | 15 | 16 | 08 | 39 |
| 25 | GODSE ISHWANKU SANJAY | 18 | 17 | 08 | 43 |

Course Coordinator



Head of the Department
Head of Department
Dept. of Mechanical Engineering
ZES's Zeal College of Engineering
& Research, Pune-411 041



**ZEAL EDUCATION SOCIETY'S
ZEAL COLLEGE OF ENGINEERING AND RESEARCH
NARHE | PUNE -41 | INDIA**



DEPARTMENT OF MECHANICAL ENGINEERING

Evaluation details of Hands on CAD/CAM/CAE (UGNX-10.0)

Academic Year: 2020-21

Duration of Course: 38 Hours (17.01.21- 26.03.21)

SEM-II

| Sr. No. | Name | Part Modelling (20) | Assembly Modelling (20) | Drafting (10) | Total Marks (50) |
|---------|----------------------------|---------------------|-------------------------|---------------|------------------|
| 1 | AMANGI CHARUDATTA UDAY | 15 | 14 | 07 | 36 |
| 2 | AWALE SHUBHAM SHIVAJI | 16 | 16 | 08 | 40 |
| 3 | BHURE VARUN DILIPBHAI | 17 | 15 | 07 | 39 |
| 4 | BINGUNDI ANIRUDH SHRINIWAS | 16 | 17 | 08 | 41 |
| 5 | BIRAJDAR VISHAL ANIL | 12 | 13 | 06 | 31 |
| 6 | CHANDANSHIVE AKASH VASANT | 14 | 15 | 07 | 36 |
| 7 | CHAVAN POOJA HAJIMALANG | 16 | 17 | 08 | 41 |
| 8 | DAIVADNYA GAYATRI MANOHAR | 14 | 15 | 07 | 36 |
| 9 | DHENE DINESH POPAT | 15 | 15 | 07 | 37 |
| 10 | DUDHANE PRASAD PRAKASH | 16 | 17 | 08 | 41 |
| 11 | FUTANE PRASANNA RAM | 14 | 15 | 07 | 36 |
| 12 | GAJARE VINAYAK POPAT | 13 | 15 | 07 | 35 |
| 13 | GARAD ANIKET SUDAM | 18 | 17 | 07 | 42 |
| 14 | GHUTE DIVYARAJ MEGHRAJ | 18 | 16 | 09 | 43 |
| 15 | GOGAWALE TANMAY PRASHANT | 15 | 17 | 07 | 39 |
| 16 | JADHAV RAJVEER HIMMAT | 14 | 17 | 08 | 39 |
| 17 | JAGATAP ABHISHEK RAJENDRA | 18 | 16 | 08 | 42 |
| 18 | JAGTAP PRASAD MAHADEV | 18 | 17 | 09 | 44 |
| 19 | JARIKOTE MAHESH BALAJI | 12 | 14 | 06 | 32 |
| 20 | JAWALGIKAR ISHA DATTATRAYA | 16 | 17 | 07 | 40 |
| 21 | KADAM PRATIK SANJAY | 15 | 15 | 07 | 37 |
| 22 | KALE ANAND JAGJEEVAN | 16 | 16 | 08 | 40 |
| 23 | KHIRID SUJIT DNYANESHWAR | 15 | 15 | 07 | 37 |
| 24 | KOCHARI ATHARV SHIVANAND | 14 | 17 | 08 | 39 |
| 25 | KORPAD PREM PRAMOD | 17 | 14 | 07 | 38 |

Course Coordinator



Head of the Department
Dept. of Mechanical Engineering
ZES's Zeal College of Engineering
& Research, Pune-41 1041



**ZEAL EDUCATION SOCIETY'S
ZEAL COLLEGE OF ENGINEERING AND RESEARCH
NARHE | PUNE -41 | INDIA**



DEPARTMENT OF MECHANICAL ENGINEERING

Evaluation details of Hands on CAD/CAM/CAE (UGNX-10.0)

Academic Year: 2020-21

Duration of Course: 38 Hours (17.01.21- 26.03.21)

SEM-II

| Sr. No. | Name | Part Modelling (20) | Assembly Modelling (20) | Drafting (10) | Total Marks (50) |
|---------|---------------------------------|---------------------|-------------------------|---------------|------------------|
| 1 | DESHMUKH KRUSHNA ACHUTRAO | 13 | 13 | 07 | 33 |
| 2 | KALE SURAJ SUNIL | 14 | 15 | 07 | 36 |
| 3 | KUNVAR KRUNALBHAI DILIPBHAI | 16 | 13 | 08 | 37 |
| 4 | NIGADE ROHIT SHIVAJI | 12 | 12 | 07 | 36 |
| 5 | PANDIT OMKAR SOMANATH | 12 | 13 | 06 | 31 |
| 6 | PARAB SWAPNIL RAVINDRA | 14 | 14 | 06 | 34 |
| 7 | PATIL DEVENDRA SUDHAKAR | 16 | 17 | 08 | 41 |
| 8 | PATIL HINDURAO KESHAVRAO | 15 | 16 | 07 | 38 |
| 9 | PATIL JAGRUT BHAGWAT | 18 | 18 | 08 | 44 |
| 10 | PATIL MAHESH UMESH | 16 | 17 | 07 | 40 |
| 11 | PATIL SAURABH SUBHASH | 18 | 16 | 08 | 42 |
| 12 | PATIL SNEHA SUNIL | 17 | 17 | 06 | 40 |
| 13 | PATIL VISHWAJEET MANIKRAO | 18 | 17 | 08 | 43 |
| 14 | PAYGUDE OMKAR ASHOK | 16 | 14 | 07 | 37 |
| 15 | PHALKE MAHESH PRADIP | 18 | 17 | 08 | 43 |
| 16 | PRATIK SANJAY PULUJKAR | 17 | 16 | 08 | 41 |
| 17 | RAJESHIRKE INDRAJEET SHASHIKANT | 13 | 13 | 07 | 33 |
| 18 | RAJIVADE ROHIT DATTATRAY | 15 | 16 | 07 | 38 |
| 19 | RAJIWADE RAHUL DILIP | 16 | 14 | 07 | 37 |
| 20 | RAJPUROHIT DHANESH RAMSINGH | 15 | 16 | 08 | 39 |
| 21 | RANSING SOHAM SANTOSH | 16 | 17 | 07 | 40 |
| 22 | RAUT SOURABH BALKRUSHNA | 15 | 15 | 07 | 37 |
| 23 | REKHALE PRASHANT SHRIMANT | 16 | 17 | 08 | 41 |
| 24 | SONAWANE NILESH SHIVAJI | 13 | 14 | 07 | 34 |
| 25 | SUKI SHANKAR SANDESH | 15 | 14 | 08 | 37 |

Course Coordinator



Head of the Department

Dept. of Mechanical Engineering
ZES's Zeal College of Engineering
& Research, Pune-41 041



DEPARTMENT OF MECHANICAL ENGINEERING

Hands on Training on Computer Aided Design (CAD) - Catia V5 R21 Summary Report

Academic Year: 2020-21
Class: T.E. & BE

Semester: I

| | |
|--------------------------------|--|
| Title of Activity/Event | Hands on Training on Computer Aided Design (CAD) - Catia V5 21 |
| Date of Activity/Event | 17.01.21-26.03.21 |
| Name of Expert/Trainer | Prof .Adewar S.S, Prof. Kulkarni S.S. Prof. M.R Kalyanshetti |
| Objective | The aim of this hands on training was to study the implementations of solid modeling and get hands-on experience on CAD modeling. Contents of this course is structured so as to cover the topics like part design, assembly, drafting, wireframe & surface, and Generative Sheet metal Design workbenches of CATIA V5 R21. |
| Summary | <p>Hands on training on Computer Aided Design (CATIA-V5R21) were successfully conducted on online mode for final year engineering (Mechanical Engineering Department, ZCOER Pune). This training is the part of skill development of the final year students to enhance their skill in CAD domain. This was conducted from 17.01.21- 26.03.21 with 38hr duration Total 75 students were participated in these hands on training.</p> <p>The resource person for this training was Prof. Adewar S .S. Prof. Kulkarni S . S. and Prof Kalyanshetti M.R. and following domain was covered through this training.</p> <ol style="list-style-type: none"> 1. Sketcher- To creat e 20 sketches 2 . Part Modeling- To c re ate 30 model 3. Drafting-To Create Industrial drawing with annotation. 4 . Assembly-To assemble more the 2 parts with con strains. 5. Sheet Metal-To create all sheet metal parts with manufacturing concepts. 6. Surfacing-To Create complex parts <p>Along with above domain also cover industrial design methodology with Industrial standards. To evaluate all participants had conducted CAD test and also train e d for industrial projects along with interview, question and answer A s the outcome of this course 2 students are placed in the</p> |

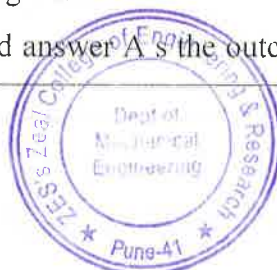



**ZEAL EDUCATION SOCIETY'S
ZEAL COLLEGE OF ENGINEERING AND RESEARCH
NARHE | PUNE -41 | INDIA**



DEPARTMENT OF MECHANICAL ENGINEERING

| | | | | | | | | | | | | | | | | |
|--------------------------|--|-----|-----|-----|-----|-----|-----|-----|-----|------|------|------|------|------|------|------|
| | <p>CAD service based company design Engineer.</p> <p>The program was coordinate d by Prof. Adewar S. S. Prof. Kulkarni S. S. and Prof Kalyanshetti M.R. under the guidance and support of Prof Godase SS. (HOD. Mechanical Engineering Department) and staff of Mechanical Engineering Department. The Program as organized under CAD/CAM/ CAE Excellence center</p> | | | | | | | | | | | | | | | |
| POs/PSOs Attained | PO1 | PO2 | PO3 | PO4 | PO5 | PO6 | PO7 | PO8 | PO9 | PO10 | PO11 | PO12 | PSO1 | PSO2 | PSO3 | PSO4 |
| | ✓ | ✓ | ✓ | ✓ | ✓ | ✓ | | | | | | ✓ | ✓ | ✓ | ✓ | ✓ |
| Outcomes | <p>The students got hands on experience through this program on CAD modeling. It helps to improve the ability to understand basics of part modeling using CATIA V5 interface and application of commands for the modules Sketcher, Part Design, Assembly Design & Drafting.</p> | | | | | | | | | | | | | | | |

Course Coordinator



Head of the Department
Head of Department
Dept. of Mechanical Engineering
ZES's Zeal College of Engineering
& Research, Pune-411 041



ZEAL
INSTITUTES

www.zealeducation.com

NARHE | PUNE | INDIA



ZEAL COLLEGE OF ENGINEERING & RESEARCH, PUNE

Department of Mechanical Engineering

CERTIFICATE OF APPRECIATION

ABHINKAR ATHARVA NILESH

for successfully completing Hands-On Training on Computer-Aided Design (CAD) – Catia V5 R19 Training Schedule from 17/01/2021 to 26/03/2021 under CAD-CAM Excellence Centre at Department of Mechanical Engineering, Zeal College of Engineering and Research Pune

Prof. S.M. Godase
HOD, Mechanical Engineering
ZCOER, Pune



Dr. A.M. Kate
Principal,
ZCOER, Pune



ZEEAL

INSTITUTES

www.zealeducation.com

NARHE | PUNE | INDIA



ZEAL COLLEGE OF ENGINEERING & RESEARCH, PUNE

Department of Mechanical Engineering

CERTIFICATE OF APPRECIATION

AJMIRE PRAJWAL KISHOR

for successfully completing Hands-On Training on Computer-Aided Design (CAD) – Catia V5 R19 Training Schedule from 17/01/2021 to 26/03/2021 under CAD-CAM Excellence Centre at Department of Mechanical Engineering, Zeal College of Engineering and Research Pune

Prof. S.M. Godase
HOD, Mechanical Engineering
ZCOER, Pune



Dr. A. M. Kate
Principal
ZCOER, Pune



**ZEAL EDUCATION SOCIETY'S
ZEAL COLLEGE OF ENGINEERING AND RESEARCH
NARHE | PUNE -41 | INDIA**



DEPARTMENT OF MECHANICAL ENGINEERING

Hands on Training on Computer Aided Design (CAD) CATIA V5R21

Index

| Sr. No | Particulars |
|---------------|---------------------------|
| 1 | Course Details |
| 2 | Course Content |
| 3 | Notice |
| 4 | List of students enrolled |
| 5 | Schedule |
| 6 | Student attendance |
| 7 | Evaluation Details |
| 8 | Activity Summary Report |
| 9 | Certificate |



**ZEAL EDUCATION SOCIETY'S
ZEAL COLLEGE OF ENGINEERING AND RESEARCH
NARHE | PUNE -41 | INDIA**



DEPARTMENT OF MECHANICAL ENGINEERING

COURSE DETAILS

| | | |
|---|--------------------------|---|
| 1 | Course Name | Hands on Training on Computer Aided Design (CAD) - Catia V5 R21 |
| 2 | Duration | 40 Hrs |
| 3 | Date | 15.05.21- 30.06.21 |
| 4 | Students enrolled | 75 |
| 5 | Learners | BE |

Course Coordinator



Head of the Department
Head of Department
Dept. of Mechanical Engineering
ZES's Zeal College of Engineering
& Research, Pune-411 041



**ZEAL EDUCATION SOCIETY'S
ZEAL COLLEGE OF ENGINEERING AND RESEARCH
NARHE | PUNE -41 | INDIA**



DEPARTMENT OF MECHANICAL ENGINEERING

Notice (Hands on Training)

Date: 21/04/2021

Hands on training program on “**Computer Aided Design (CAD) - Catia V5 R21**” for TE & BE students will be conducted from **15.05.21- 30.06.21** in the Department of Mechanical Engineering. The interested students can register to department on or before 02/05/2021.

Course Coordinator

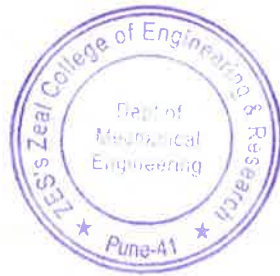

Head of the Department
Head of Department
Dept. of Mechanical Engineering
ZES's Zeal College of Engineering
& Research, Pune-411 041



ZEAL EDUCATION SOCIETY'S
ZEAL COLLEGE OF ENGINEERING AND RESEARCH
NARHE | PUNE -41 | INDIA
DEPARTMENT OF MECHANICAL ENGINEERING



List of the Students Enrolled for Hands on Training on CAM/CAM/CAE (CATIA V5R21)

Academic Year: 2020-21

Duration of Course: 40 Hours (15/05/2021 to 30/06/2021)

Class : BE

SEM-II

| S.N | Name |
|-----|-----------------------------|
| 1 | AKERKAR OMKAR SHARAD |
| 2 | ARKAL VARUN SUNIL |
| 3 | ASMAR SHARDUL VINOD |
| 4 | BAGAL SATYAJIT PUNJARAM |
| 5 | BARGAJE AJAY DAJIBA |
| 6 | BASUTKAR APRATIM AVANEENDRA |
| 7 | BENDALE TEJAS JANARDAN |
| 8 | BHIRDIKAR NINAD INAMDAR |
| 9 | BHOJ AKSHAY ANIL |
| 10 | BHOJANE RUTWIK ARVIND |
| 11 | CHATE MADHUSUDAN TUKARAM |
| 12 | CHAUDHARI ANIRUDDHA SAMPAT |
| 13 | DAKVE BHAVESH SURESH |
| 14 | DANGE PRATHAMESH MANOJKUMAR |
| 15 | DHOKALE PRASAD DATTATRAY |
| 16 | DOHALE GAURAV GENDLAL |
| 17 | GULVE KUNAL NARENDRA |
| 18 | LOKHANDE PANKAJ ROHIDAS |
| 19 | MOHOLKAR SUNIL BALASAHEB |
| 20 | MORE MAYUR KAILAS |
| 21 | MORE YASH SHANKAR |
| 22 | NIRGUDE MANOJ |
| 23 | PAREKH SMIT MILIND |
| 24 | PARMAR NARESH JAGDISH |
| 25 | POTDAR SHUBHAM SURESH |

Course Co-ordinator



Handwritten signature of the Head of Department

Head of Department
Dept. of Mechanical Engineering
ZES's Zeal College of Engineering



ZEAL EDUCATION SOCIETY'S
ZEAL COLLEGE OF ENGINEERING AND RESEARCH
NARHE | PUNE -41 | INDIA
DEPARTMENT OF MECHANICAL ENGINEERING



List of the Students Enrolled for Hands on Training on CAM/CAM/CAE (CATIA V5R21)

Academic Year: 2020-21

Duration of Course: 40 Hours (15/05/2021 to 30/06/2021)

Class : BE

SEM- II

| S.No. | Name |
|-------|----------------------------|
| 1 | ADSUL SUNIL ARJUN |
| 2 | AJURKAR MAYUR MALLAPPA |
| 3 | BHALE ASHWIN JITENDRA |
| 4 | BHISE BAJARANG VASANTRAO |
| 5 | DEOKAR SURAJ ANIL |
| 6 | DHONDGE TIRUPATI VITHALRAO |
| 7 | GAPAT RAJKUMAR ANKUSH |
| 8 | GHADWALE PRANAV KIRAN |
| 9 | GHOSPURKAR SHIVANI RAJAN |
| 10 | GUND VISHAL ACHYUT |
| 11 | JADHAV DHIRAJ VIJAYKUMAR |
| 12 | KALEKAR NILESH BALASAHEB |
| 13 | KHANDAGALE KAILAS DATTA |
| 14 | KHUSTULE TEJAS PRAVIN |
| 15 | KOHADE RAJAT RAMDAS |
| 16 | KOTWAL UMER PASHA |
| 17 | KUDALE PRANAV HEMANT |
| 18 | LABADE SHARAD NARAYAN |
| 19 | LOHOKARE TANMAY MAKRAND |
| 20 | MORE SNEHAL ROHIDAS |
| 21 | NADRE DIPAK YASHWANTA |
| 22 | SALI VINA YAK UMESH |
| 23 | SALVE RAHUL SUNIL |
| 24 | SASTIKAR ABHIRAM SHRIKANT |
| 25 | SHETE PRADEEP PRAVIN |

[Signature]

Course Co-ordinator



[Signature]
Head of Department
Department of Engineering
ZES's Zeal College of Engineering
& Research, Pune-41 041



ZEAL EDUCATION SOCIETY'S
ZEAL COLLEGE OF ENGINEERING AND RESEARCH
NARHE | PUNE -41 | INDIA
DEPARTMENT OF MECHANICAL ENGINEERING



List of the Students Enrolled for Training on CAM/CAM/CAE (CATIA V5R21)

Academic Year: 2020-21

Duration of Course: 40 Hours (15/05/2021 to 30/06/2021)

Class : BE

SEM-IV

| S.No. | Name |
|-------|---------------------------|
| 1 | JADHAV SWAPNIL UMESH |
| 2 | KAKDE KUNDAN DILIP |
| 3 | KALE SHUBHAM VASANT |
| 4 | KAMBLE VIKRAM RAJAN |
| 5 | KASPATE SANKET BAJRANG |
| 6 | KATKAR SNEHAL SUDHAKAR |
| 7 | KAUSTUBH BHASKAR SHETE |
| 8 | KHALADKAR SHUBHAM SUDAM |
| 9 | KOLI AVINASH NARSING |
| 10 | KONDE ASHITOSH NILESH |
| 11 | KUMBHAR DEEPAK BHASKAR |
| 12 | LOKARE SWAPNIL JANARDAN |
| 13 | LONARE SANKET RAMNATH |
| 14 | MANDAVKAR SHUBHAM ROHIDAS |
| 15 | MANGLEKAR SUSHANT VIJAY |
| 16 | MANJARE DHIRAJ BALU |
| 17 | MARJE PRATIK RAVINDRA |
| 18 | KAMBLE SUSHANT SHARAD |
| 19 | KATU PRERANA MOHAN |
| 20 | KENGAR SUHAS DAYANAND |
| 21 | KHAIRNAR CHETAN VIJAY |
| 22 | KAMBLE SUSHANT SHARAD |
| 23 | KATU PRERANA MOHAN |
| 24 | KENGAR SUHAS DAYANAND |
| 25 | KHAIRNAR CHETAN VIJAY |

Course Co-ordinator



Head of Department
Dept. of Mechanical Engineering

ZEAL's Zeal College of Engineering
& Research, Pune-411 024



**ZEAL EDUCATION SOCIETY'S
ZEAL COLLEGE OF ENGINEERING AND RESEARCH
NARHE | PUNE -41 | INDIA**



DEPARTMENT OF MECHANICAL ENGINEERING

Notice (Hands on Training schedule)

Date: 12/05/2021

All enrolled students for Hands on training program on “**Computer Aided Design (CAD) - Catia V5 R21**” are informed that training is scheduled from 15/05/2021 to 30/06/2021. Please find list of batch wise enrolled students on respective WhatsApp group.

| Batch | Time |
|-------|--------------|
| 1 | 1.00 to 3.00 |
| 2 | 3.00 to 5.00 |
| 3 | 5.00 to 7.00 |

Course Coordinator

Head of the Department

Head of Department
Dept. of Mechanical Engineering
ZES's Zeal College of Engineering
& Research, Pune-411 041





DEPARTMENT OF MECHANICAL ENGINEERING

Schedule

| Week | DAY | Details of Module |
|--------|-----|---|
| Week 1 | 1 | Sketching Modelling |
| | 2 | Introduction to 2D&.3D, Basic concepts. Introduction to Unigraphics NX, User interface, WCS, Absolute coordinate Application. |
| | 3 | Sketching commands, Sketch positioning, Basic idea behind constraints, |
| | 4 | Sketching Practice session |
| | 5 | Part Modeling |
| | 6 | Extrude, Revolve, Edge Blend, Chamfer, |
| Week 2 | 7 | Hole, Datums(Point, Axis, Plane) . Draft body ,Shell, Pattern (Linear , circular).Rib, Sweep Along Guide, |
| | 8 | Variational sweep, Swept, Edit work section, copy feature, paste, scale body, selection filter |
| | 9 | Basic primitives (Block, Cylinder, Cone and Sphere,)Boss .Pad, Pocket, Grooves lot, thread, |
| | 10 | Combine (Unit, Subtracts, Intersect),time stamp order, apply material, measure - bodies |
| Week 3 | 11 | Part Modeling Practice session |
| | 12 | Drafting |
| | 13 | Sheet properties, New sheet ,Edit Sheet, Base view, View Wizard, Dimensions and types, Note |
| | 14 | Projected/Auxiliary View, Section view, Detail view, View brake: breakout section ,dimension tolerances |
| | 15 | Datum, Datum target, Feature control frame, center mark, cross hatch , surface finish , weld symbol |
| | 16 | Assembly |
| Week 4 | 17 | Bottom up Assembly: Add. move Component. Assembly constraints Pattern components . |
| | 18 | Top Down: Create New, Wave geometry link, exploded view clearance, creation Assembly Drafting : BOM, Ballon |
| | 19 | TEST 1 |
| | 20 | TEST 2 |

Course Coordinator



Head of the Department
Head of Department
Dept. of Mechanical Engineering
ZES's Zeal College of Engineering
& Research, Pune-411 041



List of the Students Enrolled for Hands on Training on CAM/CAM/CAE (CATIA V5R21)

Academic Year: 2020-21

Duration of Course: 40 Hours (15/05/2021 to 30/06/2021)

Class : BE

SEM-II

| S.N | Name | 15 | 16 | 21 | 22 | 23 | 28 | 29 | 30 | 4 | 5 | 6 | 11 | 12 | 13 | 18 | 19 | 20 | 25 | 26 | 30 | |
|-----|-----------------------------|----|----|----|----|----|----|----|----|---|---|---|----|----|----|----|----|----|----|----|----|---|
| 1 | AKERKAR OMKAR SHARAD | P | P | P | P | P | P | P | P | P | P | P | P | P | P | P | P | P | P | P | P | P |
| 2 | ARKAL VARUN SUNIL | P | A | P | P | P | P | P | P | P | P | P | P | P | P | A | P | P | P | P | P | P |
| 3 | ASMAR SHARDUL VINOD | P | P | P | P | P | P | P | P | P | P | P | P | P | P | P | P | P | P | P | P | P |
| 4 | BAGAL SATYAJIT PUNJARAM | P | P | P | P | P | P | P | P | P | P | P | P | P | P | P | P | P | P | P | P | P |
| 5 | BARGAJE AJAY DAJIBA | P | P | P | P | P | A | P | P | P | P | P | P | P | P | P | P | P | P | P | P | P |
| 6 | BASUTKAR APRATIM AVANEENDRA | P | P | A | P | P | P | P | P | P | P | P | P | P | P | P | P | P | P | P | P | P |
| 7 | BENDALE TIJAS JANARDAN | P | P | P | P | P | P | P | P | P | P | P | P | P | P | P | P | P | P | P | P | P |
| 8 | BHIRDIKAR NINAD INAMDAR | P | P | P | P | P | P | P | P | P | P | P | P | P | P | P | P | P | P | P | P | P |
| 9 | BHOJ AKSHAY ANIL | P | P | P | P | P | P | P | P | P | P | P | P | P | P | P | P | P | P | P | P | P |
| 10 | BHOJANE RUTWIK ARVIND | P | P | P | P | P | P | P | P | P | P | P | P | P | P | P | P | P | P | P | P | P |
| 11 | CHATE MADHUSUDAN TUKARAM | P | P | P | P | P | P | P | P | P | P | P | P | P | P | P | P | P | P | P | P | P |
| 12 | CHAUDHARI ANIRUDDHA SAMPAT | P | P | P | P | P | A | P | P | P | P | P | P | P | P | P | P | P | P | P | P | P |
| 13 | DAKVE BHAVESH SURESH | P | P | P | P | P | P | P | P | P | P | P | P | P | P | P | P | P | P | P | P | P |
| 14 | DANGE PRATHAMESH MANOJKUMAR | P | P | P | P | P | P | P | P | P | P | P | P | P | P | P | P | P | P | P | P | P |
| 15 | DHOKALE PRASAD DATTA TRAY | A | P | P | P | P | P | P | P | A | P | P | P | P | P | P | P | P | P | P | P | P |
| 16 | DOHALE GAURAV GENDLAL | P | P | P | P | P | P | P | P | P | P | P | P | P | P | P | P | P | P | P | P | P |
| 17 | GULVE KUNAL NARENDRA | P | P | P | P | P | P | P | P | P | P | P | P | P | P | P | P | P | P | A | P | P |
| 18 | LOKHANDE PANKAJ ROHIDAS | P | P | P | P | P | P | P | P | P | P | P | P | P | P | P | P | A | P | P | P | P |
| 19 | MOHOLKAR SUNIL BALASAHEB | P | P | P | P | P | P | P | A | P | P | P | P | P | P | P | P | P | P | P | P | P |
| 20 | MORE MAYUR KAILAS | P | P | P | P | P | P | P | P | P | P | P | P | P | P | P | P | P | P | P | P | P |
| 21 | MORE YASH SHANKAR | P | P | P | P | P | P | P | P | P | P | P | P | P | P | P | P | P | P | P | P | P |
| 22 | NIRGUDE MANOJ | P | A | P | P | P | P | P | P | P | P | P | P | P | P | P | P | P | P | P | P | P |
| 23 | PAREKH SMIT MILIND | P | P | A | P | P | P | P | P | P | A | P | P | P | P | P | P | P | P | P | P | P |
| 24 | PARMAR NARESH JAGDISH | P | P | P | P | P | P | P | P | P | P | P | P | P | P | P | P | P | P | P | A | P |
| 25 | POTDAR SHUBHAM SURESH | P | P | A | P | P | P | P | P | P | P | P | P | P | P | P | P | P | P | P | P | P |

Course Co-ordinator



Head of Department
 Dept. of Mechanical Engineering
 ZES's Zeal College of Engineering



List of the Students Enrolled for Hands on Training on CAM/CAM/CAE (CATIA V5R21)

Academic Year: 2020-21
 Duration of Course: 40 Hours (15/05/2021 to 30/06/2021)

Class : BE
SEM-II

| S.N o. | Name | 15 | 16 | 21 | 22 | 23 | 28 | 29 | 30 | 4 | 5 | 6 | 6 | 11 | 12 | 13 | 18 | 19 | 20 | 25 | 26 | 30 | |
|--------|----------------------------|----|----|----|----|----|----|----|----|---|---|---|---|----|----|----|----|----|----|----|----|----|---|
| 1 | ADSUL SUNIL ARJUN | P | P | P | P | P | P | P | P | P | P | P | P | P | P | P | P | P | P | P | P | P | P |
| 2 | AJURKAR MAYUR MALLAPPA | P | P | A | A | P | P | P | P | P | P | P | P | P | P | P | P | P | P | P | P | P | P |
| 3 | BHALE ASHWIN JITENDRA | P | P | P | P | P | P | P | P | P | P | P | P | P | P | A | P | P | P | P | P | P | P |
| 4 | BHISE BAJARANG VASANTRAO | P | P | P | P | P | P | P | P | P | P | P | P | P | P | P | A | P | P | P | P | P | P |
| 5 | DEOKAR SURAJ ANIL | P | P | P | P | P | P | P | P | A | P | P | P | P | P | P | P | P | P | P | P | P | P |
| 6 | DHONDGE TIRUPATI VITHALRAO | P | P | P | P | P | P | P | P | P | P | P | P | P | P | P | P | P | P | P | P | P | P |
| 7 | GAPAT RAJKUMAR ANKUSH | P | P | P | P | P | P | P | P | P | P | P | P | P | P | P | P | P | P | P | P | P | P |
| 8 | GHADWALE PRANAV KIRAN | P | P | P | P | A | P | P | P | P | P | P | P | P | P | P | P | A | P | P | P | P | P |
| 9 | GHOSPURKAR SHIVANI RAJAN | P | P | P | P | P | P | P | P | P | P | P | P | P | P | P | P | P | P | P | P | P | P |
| 10 | GUND VISHAL ACHYUT | P | P | P | P | P | P | P | P | P | P | P | P | P | P | P | P | P | P | P | P | P | P |
| 11 | JADHAV DHIRAJ VIJAYKUMAR | P | P | P | P | P | P | P | P | P | P | A | P | P | P | P | P | P | P | P | P | P | P |
| 12 | KALEKAR NILESH BALASAHEB | P | P | A | P | P | P | P | P | P | P | P | P | P | P | P | P | P | P | P | P | P | P |
| 13 | KHANDAGALE KAILAS DATTA | P | P | P | P | A | P | P | P | P | P | P | P | P | P | P | P | A | P | P | P | P | P |
| 14 | KHUSTULE TEJAS PRAVIN | P | P | P | P | P | P | P | P | P | P | P | P | P | P | P | P | P | P | P | P | P | P |
| 15 | KOHADDE RAJAT RAMDAS | P | P | P | P | P | P | P | P | P | P | P | P | P | P | P | P | P | P | P | P | P | P |
| 16 | KOTWAL UMER PASHA | P | P | P | P | P | P | A | P | P | P | P | P | P | P | P | P | P | P | P | P | P | P |
| 17 | KUDALE PRANAV HEMANT | P | A | P | P | P | P | P | P | P | P | P | P | P | P | P | P | P | P | P | P | P | P |
| 18 | LABADE SHARAD NARAYAN | P | P | P | P | P | P | P | P | P | P | P | P | P | P | P | A | P | P | P | P | P | P |
| 19 | LOHOKARE TANMAY MAKRAND | P | P | P | P | P | P | P | P | P | P | P | P | P | P | P | P | P | P | P | A | P | P |
| 20 | MORE SNEHAL ROHIDAS | P | P | P | P | P | P | P | P | P | P | P | P | P | P | P | P | P | P | P | P | P | P |
| 21 | NADRE DIPAK YASHWANTA | P | P | P | P | P | P | P | P | P | P | P | P | P | P | P | P | P | P | P | P | P | P |
| 22 | SALI VINAYAK UMESH | P | P | P | P | P | P | P | P | P | P | P | P | P | P | P | P | P | P | P | P | P | P |
| 23 | SALVE RAHUL SUNIL | P | P | P | P | P | P | A | P | P | P | P | P | P | P | P | P | P | P | P | P | P | P |
| 24 | SASTIKAR ABHIRAM SHRIKANT | P | P | P | P | P | A | P | P | P | P | P | P | P | P | P | P | P | P | P | P | P | P |
| 25 | SHETE PRATIK PRAVIN | P | P | P | A | P | P | P | P | P | P | P | P | P | P | P | P | P | P | P | P | P | P |



Course Co-ordinator

Amish
 Head of Department



List of the Students Enrolled for Hands on Training on CAM/CAM/CAE (CATIA V5R21)

Academic Year: 2020-21

Duration of Course: 40 Hours (15/05/2021 to 30/06/2021)

Class : BE

SEM- II

| S.N o. | Name | 15 | 16 | 21 | 22 | 23 | 28 | 29 | 30 | 4 | 5 | 6 | 11 | 12 | 13 | 18 | 19 | 20 | 25 | 26 | 30 | |
|--------|---------------------------|----|----|----|----|----|----|----|----|---|---|---|----|----|----|----|----|----|----|----|----|---|
| 1 | JADHAV SWAPNIL UMESH | P | P | P | P | P | A | P | P | P | P | P | P | P | P | P | P | P | P | P | P | P |
| 2 | KAKDE KUNDAN DILIP | P | A | P | P | P | P | P | P | P | P | P | P | P | A | P | P | P | P | P | P | P |
| 3 | KALE SHUBHAM VASANT | P | P | P | P | P | P | P | P | P | P | P | P | P | P | P | P | P | P | P | P | P |
| 4 | KAMBLE VIKRAM RAJAN | P | P | P | P | P | P | P | P | P | P | P | P | P | P | P | P | P | P | P | P | P |
| 5 | KASPATE SANKET BAJRANG | P | P | P | P | P | A | P | P | P | P | P | P | P | P | P | P | P | P | P | P | P |
| 6 | KATKAR SNEHAL SUDHAKAR | P | P | P | P | P | P | P | P | P | P | P | P | P | P | P | P | P | P | P | P | P |
| 7 | KAUSTUBH BHASKAR SHETE | P | P | P | P | P | P | P | P | P | P | P | P | P | P | P | P | P | P | P | P | P |
| 8 | KHALADKAR SHUBHAM SUDAM | P | P | P | P | P | P | P | P | P | P | P | P | P | A | P | P | P | P | P | P | P |
| 9 | KOLI AVINASH NARSING | P | A | P | P | P | P | P | P | P | P | P | P | A | P | P | P | P | P | P | P | P |
| 10 | KONDE ASHITOSH NILESH | P | P | P | P | P | P | P | P | P | P | P | P | P | A | P | P | P | P | P | P | P |
| 11 | KUMBHAR DEEPAK BHASKAR | P | P | P | P | P | P | P | P | P | P | P | P | P | P | P | P | P | P | P | P | P |
| 12 | LOKARE SWAPNIL JANARDAN | P | P | P | P | A | P | P | P | P | P | P | P | P | P | P | P | P | P | P | P | P |
| 13 | LONARE SANKET RAMNATH | A | P | P | P | P | P | P | P | P | P | P | P | P | P | P | P | P | P | P | P | P |
| 14 | MANDAVKAR SHUBHAM ROHIDAS | P | P | P | P | P | P | P | P | P | P | P | P | P | P | A | P | P | P | P | P | P |
| 15 | MANGLEKAR SUSHANT VIJAY | P | P | P | P | P | P | A | P | P | P | P | P | P | P | P | P | P | P | P | P | P |
| 16 | MANJARE DHIRAJ BALU | P | P | P | P | P | P | P | P | P | P | P | P | P | P | P | P | P | P | P | P | P |
| 17 | MARJE PRATIK RAVINDRA | P | P | P | P | P | P | P | P | P | P | P | P | P | P | P | P | P | P | P | P | P |
| 18 | KAMBLE SUSHANT SHARAD | P | P | P | P | P | P | A | P | P | P | P | P | P | P | P | P | P | P | P | P | P |
| 19 | KATU PRERANA MOHAN | P | P | P | P | P | P | P | P | A | P | P | P | P | P | A | P | P | P | P | P | P |
| 20 | KENGAR SUHAS DAYANAND | P | P | A | P | P | P | P | A | P | P | P | P | P | P | P | P | P | P | P | P | P |
| 21 | KHAIARNAR CHETAN VIJAY | P | P | P | P | P | P | P | P | P | P | P | P | P | P | P | P | P | P | P | P | P |
| 22 | KAMBLE SUSHANT SHARAD | P | P | P | P | P | P | P | P | P | P | P | P | P | P | P | P | P | P | P | P | P |
| 23 | KATU PRERANA MOHAN | P | P | P | P | P | A | P | P | P | P | P | P | P | P | P | P | P | P | P | P | A |
| 24 | KENGAR SUHAS DAYANAND | P | P | P | P | P | P | P | P | P | P | P | P | P | P | P | P | P | P | P | P | P |
| 25 | KHAIARNAR CHETAN VIJAY | P | P | P | P | P | P | P | P | P | P | P | P | P | P | P | P | P | P | P | P | P |



Alkhan

Course Co-ordinator



DEPARTMENT OF MECHANICAL ENGINEERING

Test on Hands on CAD/CAM/CAE (UGNX-10.0)

Academic Year: 2020-21

SEM-II

Time: 2 Hrs

Marks: 50

Q1. V-Block Assembly: Create all the components of the V-Block assembly and then assemble them, as shown in Figure 1. The dimensions of the components are shown in Figures 2 and 2.

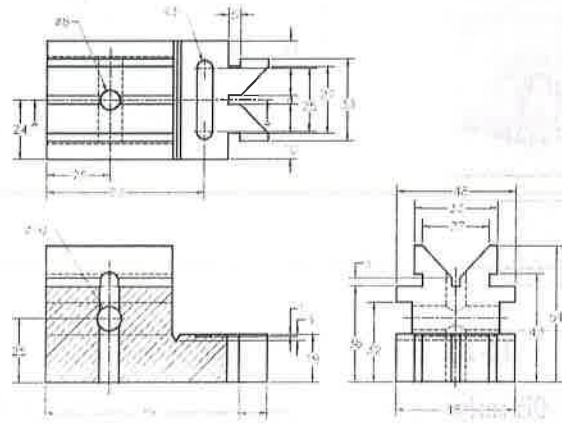
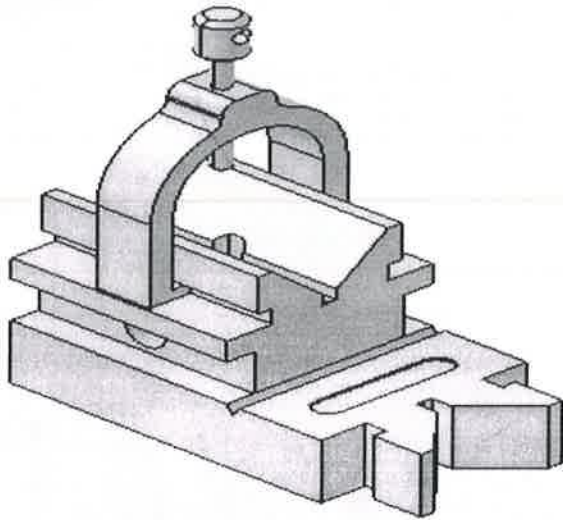

Figure 2 Views and dimensions of the V-Block body.

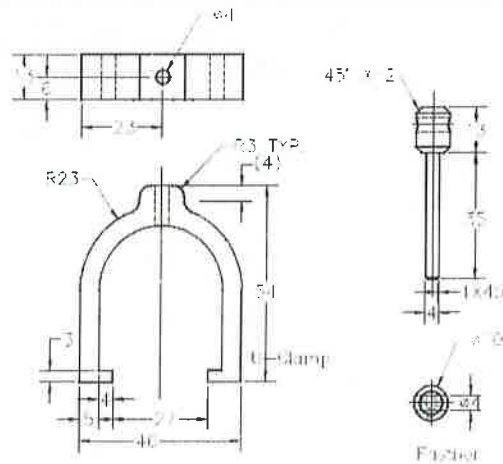

Figure 3 Views and dimensions of the U-Clamp and Fastener.

Course Coordinator



Shukin
Head of the Department
Head of Department
Dept. of Mechanical Engineering
ZES's Zeal College of Engineering
& Research, Pune-411 041



**ZEAL EDUCATION SOCIETY'S
ZEAL COLLEGE OF ENGINEERING AND RESEARCH
NARHE | PUNE -41 | INDIA**



DEPARTMENT OF MECHANICAL ENGINEERING

Evaluation details of Hands on CAM/CAM/CAE (UGNX-10.0)

Academic Year: 2020-21

Duration of Course: 40 Hours

SEM-II

| Sr. No. | Name | Part Modelling (20) | Assembly Modelling (20) | Drafting (10) | Total Marks (50) |
|---------|-----------------------------|---------------------|-------------------------|---------------|------------------|
| 1 | AKERKAR OMKAR SHARAD | 16 | 15 | 07 | 38 |
| 2 | ARKAL VARUN SUNIL | 17 | 16 | 08 | 41 |
| 3 | ASMAR SHARDUL VINOD | 14 | 15 | 07 | 36 |
| 4 | BAGAL SATYAJIT PUNJARAM | 16 | 17 | 08 | 41 |
| 5 | BARGAJE AJAY DAJIBA | 15 | 14 | 07 | 36 |
| 6 | BASUTKAR APRATIM AVANEENDRA | 18 | 17 | 08 | 43 |
| 7 | BENDALE TEJAS JANARDAN | 12 | 13 | 06 | 31 |
| 8 | BHIRDIKAR NINAD INAMDAR | 13 | 14 | 08 | 35 |
| 9 | BHOJ AKSHAY ANIL | 16 | 17 | 08 | 41 |
| 10 | BHOJANE RUTWIK ARVIND | 17 | 18 | 09 | 44 |
| 11 | CHATE MADHUSUDAN TUKARAM | 18 | 18 | 08 | 44 |
| 12 | CHAUDHARI ANIRUDDHA SAMPAT | 12 | 13 | 07 | 32 |
| 13 | DAKVE BHAVESH SURESH | 13 | 13 | 06 | 32 |
| 14 | DANGE PRATHAMESH MANOJKUMAR | 17 | 16 | 05 | 38 |
| 15 | DHOKALE PRASAD DATTATRAY | 14 | 13 | 07 | 34 |
| 16 | DOHALE GAURAV GENLAL | 13 | 14 | 06 | 33 |
| 17 | GULVE KUNAL NARENDRA | 15 | 14 | 07 | 36 |
| 18 | LOKHANDE PANKAJ ROHIDAS | 18 | 17 | 08 | 43 |
| 19 | MOHOLKAR SUNIL BALASAHEB | 15 | 14 | 07 | 36 |
| 20 | MORE MAYUR KAILAS | 13 | 12 | 06 | 31 |
| 21 | MORE YASH SHANKAR | 17 | 18 | 09 | 44 |
| 22 | NIRGUDE MANOJ | 18 | 18 | 09 | 45 |
| 23 | PAREKH SMIT MILIND | 16 | 15 | 08 | 39 |
| 24 | PARMAR NARESH JAGDISH | 14 | 14 | 06 | 34 |
| 25 | POTDAR SHUBHAM SURESH | 16 | 15 | 07 | 38 |

Course Coordinator



Head of the Department
Dept. of Mechanical Engineering
ZES's Zeal College of Engineering
& Research, Pune-411 041



**ZEAL EDUCATION SOCIETY'S
ZEAL COLLEGE OF ENGINEERING AND RESEARCH
NARHE | PUNE -41 | INDIA**



DEPARTMENT OF MECHANICAL ENGINEERING

Evaluation details of Hands on CAM/CAM/CAE (UGNX-10.0)

Academic Year: 2020-21

Duration of Course: 40 Hours

SEM-II

| Sr. No. | Name | Part Modelling (20) | Assembly Modelling (20) | Drafting (10) | Total Marks (50) |
|---------|----------------------------|---------------------|-------------------------|---------------|------------------|
| 1 | ADSUL SUNIL ARJUN | 15 | 14 | 07 | 36 |
| 2 | AJURKAR MAYUR MALLAPPA | 13 | 14 | 08 | 35 |
| 3 | BHALE ASHWIN JITENDRA | 17 | 16 | 07 | 40 |
| 4 | BHISE BAJARANG VASANTRAO | 16 | 15 | 08 | 39 |
| 5 | DEOKAR SURAJ ANIL | 16 | 16 | 07 | 39 |
| 6 | DHONDGE TIRUPATI VITHALRAO | 17 | 17 | 08 | 42 |
| 7 | GAPAT RAJKUMAR ANKUSH | 15 | 13 | 06 | 34 |
| 8 | GHADWALE PRANAV KIRAN | 16 | 17 | 08 | 41 |
| 9 | GHOSPURKAR SHIVANI RAJAN | 17 | 17 | 07 | 41 |
| 10 | GUND VISHAL ACHYUT | 12 | 12 | 06 | 30 |
| 11 | JADHAV DHIRAJ VIJAYKUMAR | 17 | 18 | 09 | 44 |
| 12 | KALEKAR NILESH BALASAHEB | 16 | 15 | 08 | 39 |
| 13 | KHANDAGALE KAILAS DATTA | 14 | 16 | 07 | 37 |
| 14 | KHUSTULE TEJAS PRAVIN | 15 | 15 | 08 | 38 |
| 15 | KOHADE RAJAT RAMDAS | 15 | 16 | 07 | 38 |
| 16 | KOTWAL UMER PASHA | 17 | 18 | 08 | 43 |
| 17 | KUDALE PRANAV HEMANT | 18 | 16 | 08 | 42 |
| 18 | LABADE SHARAD NARAYAN | 17 | 16 | 08 | 41 |
| 19 | LOHOKARE TANMAY MAKRAND | 12 | 13 | 06 | 31 |
| 20 | MORE SNEHAL ROHIDAS | 14 | 12 | 07 | 33 |
| 21 | NADRE DIPAK YASHWANTA | 13 | 14 | 06 | 33 |
| 22 | SALI VINAYAK UMESH | 12 | 12 | 06 | 30 |
| 23 | SALVE RAHUL SUNIL | 16 | 15 | 08 | 39 |
| 24 | SASTIKAR ABHIRAM SHRIKANT | 17 | 16 | 08 | 41 |
| 25 | SHETE PRATIK PRAVIN | 18 | 17 | 09 | 44 |

Course Coordinator



Pratik
Head of Department
Dept. of Mechanical Engineering
ZES's Zeal College of Engineering
& Research, Pune-411 041



**ZEAL EDUCATION SOCIETY'S
ZEAL COLLEGE OF ENGINEERING AND RESEARCH
NARHE | PUNE -41 | INDIA**



DEPARTMENT OF MECHANICAL ENGINEERING

Evaluation details of Hands on CAM/CAM/CAE (UGNX-10.0)

Academic Year: 2020-21

Duration of Course: 40 Hours

SEM-II

| Sr. No. | Name | Part Modelling (20) | Assembly Modelling (20) | Drafting (10) | Total Marks (50) |
|---------|---------------------------|---------------------|-------------------------|---------------|------------------|
| 1 | JADHAV SWAPNIL UMESH | 15 | 16 | 08 | 39 |
| 2 | KAKDE KUNDAN DILIP | 14 | 15 | 07 | 36 |
| 3 | KALE SHUBHAM VASANT | 18 | 15 | 08 | 41 |
| 4 | KAMBLE VIKRAM RAJAN | 17 | 18 | 08 | 43 |
| 5 | KASPATE SANKET BAJRANG | 14 | 15 | 07 | 37 |
| 6 | KATKAR SNEHAL SUDHAKAR | 17 | 17 | 08 | 42 |
| 7 | KAUSTUBH BHASKAR SHETE | 18 | 16 | 07 | 41 |
| 8 | KHALADKAR SHUBHAM SUDAM | 16 | 15 | 08 | 39 |
| 9 | KOLI AVINASH NARSING | 14 | 13 | 07 | 34 |
| 10 | KONDE ASHITOSH NILESH | 18 | 18 | 08 | 44 |
| 11 | KUMBHAR DEEPAK BHASKAR | 16 | 17 | 08 | 41 |
| 12 | LOKARE SWAPNIL JANARDAN | 13 | 14 | 07 | 34 |
| 13 | LONARE SANKET RAMNATH | 12 | 14 | 06 | 32 |
| 14 | MANDAVKAR SHUBHAM ROHIDAS | 16 | 15 | 08 | 39 |
| 15 | MANGLEKAR SUSHANT VIJAY | 15 | 17 | 08 | 40 |
| 16 | MANJARE DHIRAJ BALU | 15 | 16 | 07 | 38 |
| 17 | MARJE PRATIK RAVINDRA | 12 | 13 | 06 | 31 |
| 18 | KAMBLE SUSHANT SHARAD | 13 | 12 | 07 | 32 |
| 19 | KATU PRERANA MOHAN | 17 | 16 | 08 | 41 |
| 20 | KENGAR SUHAS DAYANAND | 14 | 15 | 07 | 36 |
| 21 | KHAIRNAR CHETAN VIJAY | 16 | 17 | 08 | 41 |
| 22 | KAMBLE SUSHANT SHARAD | 16 | 15 | 08 | 39 |
| 23 | KATU PRERANA MOHAN | 14 | 13 | 07 | 34 |
| 24 | KENGAR SUHAS DAYANAND | 13 | 14 | 06 | 33 |
| 25 | KHAIRNAR CHETAN VIJAY | 17 | 18 | 08 | 43 |

Course Coordinator



Head of the Department
Head of Department
Dept. of Mechanical Engineering
ZES's Zeal College of Engineering
& Research, Pune-411 041



DEPARTMENT OF MECHANICAL ENGINEERING

Hands on Training on Computer Aided Design (CAD) - Catia V5 R21 Summary Report

Academic Year: 2020-21
Class: T.E. & BE

Semester: I

| | |
|--------------------------------|--|
| Title of Activity/Event | Hands on Training on Computer Aided Design (CAD) - Catia V5 21 |
| Date of Activity/Event | 15.05.21- 30.06.21 |
| Name of Expert/Trainer | Prof .Adewar S.S, Prof. Kulkarni S.S. Prof. M.R Kalyanshetti |
| Objective | The aim of this hands on training was to study the implementations of solid modeling and get hands-on experience on CAD modeling. Contents of this course is structured so as to cover the topics like part design, assembly, drafting, wireframe & surface, and Generative Sheet metal Design workbenches of CATIA V5 R21. |
| Summary | <p>Hands on training on Computer Aided Design (CATIA-V5R21) were successfully conducted on online mode for final year engineering (Mechanical Engineering Department, ZCOER Pune). This training is the part of skill development of the final year students to enhance their skill in CAD domain. This was conducted from 15.05.21- 30.06.21 with 40 hr duration Total 75 students were participated in these hands on training.</p> <p>The resource person for this training was Prof. Adewar S .S. Prof. Kulkarni S . S. and Prof Kalyanshetti M.R. and following domain was covered through this training.</p> <ol style="list-style-type: none"> 1. Sketcher- To creat e 20 sketches 2 . Part Modeling- To c re ate 30 model 3. Drafting-To Create Industrial drawing with annotation. 4 . Assembly-To assemble more the 2 parts with con strains. 5. Sheet Metal-To create all sheet metal parts with manufacturing concepts, 6. Surfacing-To Create complex parts <p>Along with above domain also cover industrial design methodology with Industrial standards. To evaluate all participants had conducted CAD test and also train e d for industrial projects along with interview, question and answer As the outcome of this course 2 students are placed in the</p> |

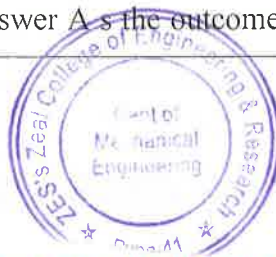



**ZEAL EDUCATION SOCIETY'S
ZEAL COLLEGE OF ENGINEERING AND RESEARCH
NARHE | PUNE -41 | INDIA**



DEPARTMENT OF MECHANICAL ENGINEERING

| | | | | | | | | | | | | | | | | |
|--------------------------|--|-----|-----|-----|-----|-----|-----|-----|-----|------|------|------|------|------|------|------|
| | <p>CAD service based company design Engineer.</p> <p>The program was coordinate d by Prof. Adewar S. S. Prof. Kulkarni S. S. and Prof Kalyanshetti M.R. under the guidance and support of Prof Godase SS. (HOD. Mechanical Engineering Department) and staff of Mechanical Engineering Department. The Program as organized under CAD/CAM/ CAE Excellence center</p> | | | | | | | | | | | | | | | |
| POs/PSOs Attained | PO1 | PO2 | PO3 | PO4 | PO5 | PO6 | PO7 | PO8 | PO9 | PO10 | PO11 | PO12 | PSO1 | PSO2 | PSO3 | PSO4 |
| | ✓ | ✓ | ✓ | ✓ | ✓ | ✓ | | | | | | ✓ | ✓ | ✓ | ✓ | ✓ |
| Outcomes | <p>The students got hands on experience through this program on CAD modeling. It helps to improve the ability to understand basics of part modeling using CATIA V5 interface and application of commands for the modules Sketcher, Part Design, Assembly Design & Drafting.</p> | | | | | | | | | | | | | | | |

Course Coordinator



Head of the Department



ZEAL
INSTITUTES

www.zealeducation.com

NARHE | PUNE | INDIA



ZEAL COLLEGE OF ENGINEERING & RESEARCH PUNE

Department of Mechanical Engineering

CERTIFICATE OF APPRECIATION

AKERKAR OMKAR SHARAD

for successfully completing Hands-On Training on Computer-Aided Design (CAD) – Catia V5 R19 Training Schedule from 15/05/2021 to 30/06/2021 under CAD-CAM Excellence Centre at Department of Mechanical Engineering, Zeal College of Engineering and Research Pune

Prof. S.M. Godase

Prof. S.M. Godase
HOD, Mechanical Engineering
ZCOER, Pune



Dr. A. M. Kate

Dr. A. M. Kate
Principal,
ZCOER, Pune